

# Hi\*Lite® XL Transmission Insulators

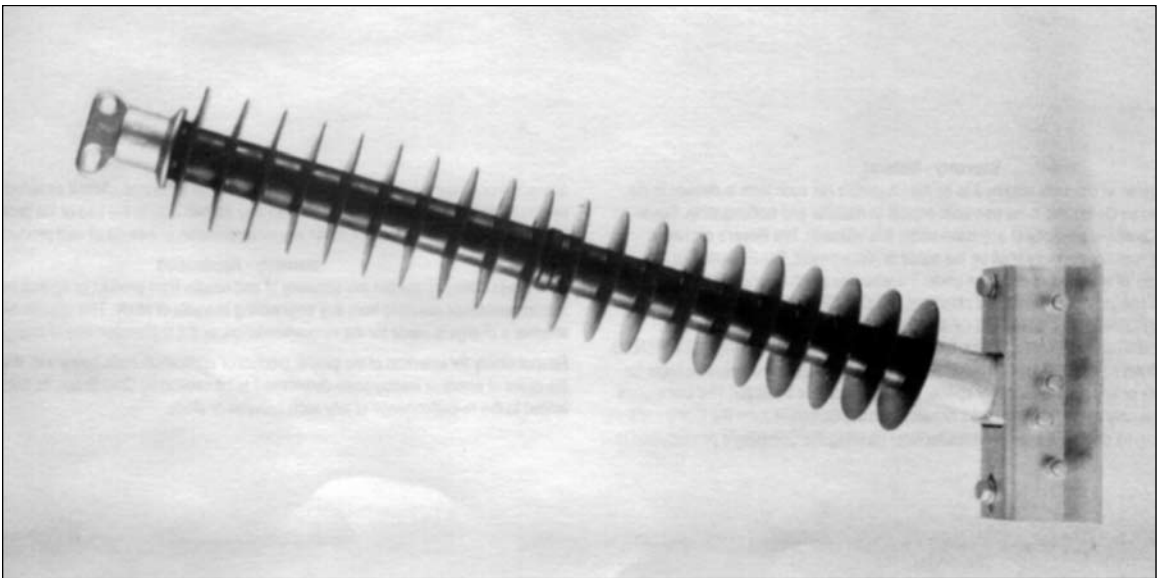

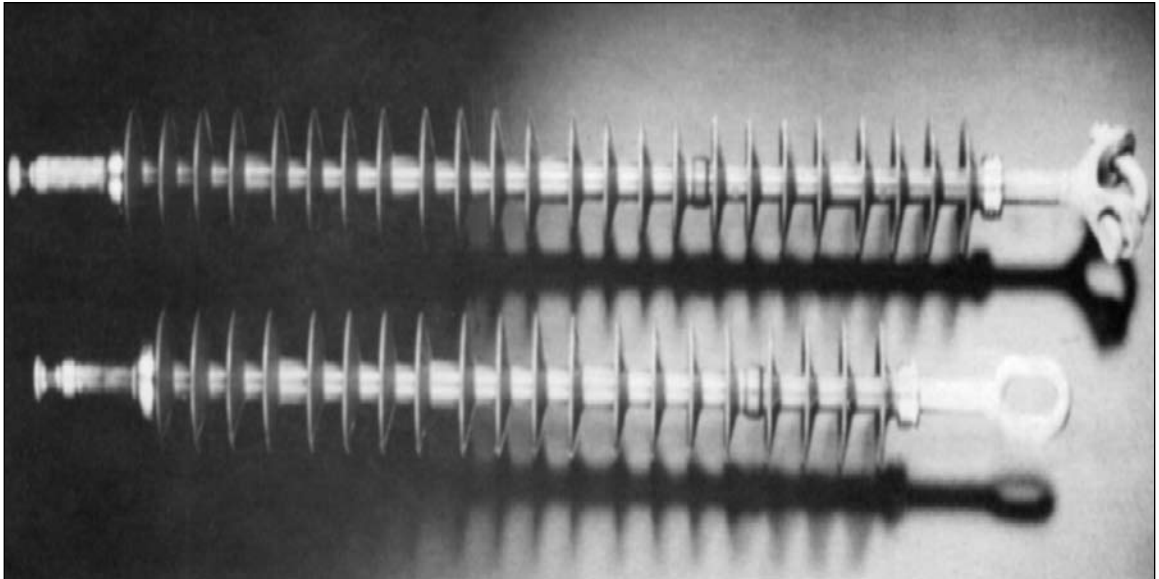

#### **Warranty - Material**

Hubbell Power Systems, Inc. warrants all products sold by it to be merchantable (as such term is defined in the Uniform Commercial Code) and to be free from defects in material and workmanship. Buyer must notify the Company promptly of any claim under this warranty. The Buyer's exclusive remedy for breach of this warranty shall be the repair or replacement, F.O.B. factory, at the Company's option, of any product defective under the warranty which is returned to the Company within one year from the date of shipment. NO OTHER WARRANTY, WHETHER EXPRESS OR ARISING BY OPERATION OF LAW, COURSE OF DEALING, USAGE OF TRADE OR OTHERWISE IMPLIED, SHALL EXIST IN CONNECTION WITH THE COMPANY'S PRODUCTS OR ANY SALE OR USE THEREOF. The Company shall in no event be liable for any loss of profits or any consequential or special damages incurred by Buyer. The Company's warranty shall run only to the first Buyer of a product from the Company, from the Company's distributor, or from an original equipment manufacturer reselling the Company's product, and is

non-assignable and non-transferable and shall be of no force and effect if asserted by any person other than such first Buyer. This warranty applies only to the use of the product as intended by Seller and does not cover any misapplication or misuse of said product.

#### **Warranty - Application**

Hubbell Power Systems, Inc. does not warrant the accuracy of and results from product or system performance recommendations resulting from any engineering analysis or study. This applies regardless of whether a charge is made for the recommendation, or if it is provided free of charge.

Responsibility for selection of the proper product or application rests solely with the purchaser. In the event of errors or inaccuracies determined to be caused by Hubbell Power Systems, Inc., its liability will be limited to the re-performance of any such analysis or study.

**NOTE: Because Hubbell has a policy of continuous product improvement, we reserve the right to change design and specifications without notice.**  
©Copyright 2006 Hubbell/Ohio Brass • 1850 Richland Avenue, East • Aiken, SC 29801

# Hi\*Lite<sup>®</sup> XL Transmission Insulators

**Section  
26**

<b>Suspensions</b>	<b>A</b>
<b>Line Posts</b>	<b>B</b>
<b>Braced Posts</b>	<b>C</b>
<b>Station Posts</b>	<b>D</b>
<b>Sample Polymer Specs</b>	<b>E</b>



# Hi\*Lite<sup>®</sup> XL Suspension Insulators

A

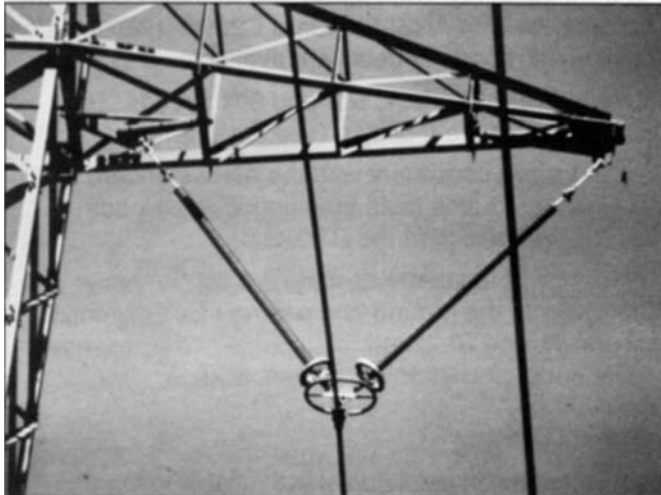

## Table of Contents

	Page
Design .....	26-6
Rod .....	26-6
End Fittings.....	26-6
Weathersheds .....	26-6
Interface.....	26-6
Leakage Distance.....	26-6
Washability .....	26-6
Mechanical Ratings .....	26-6
Lengths Available .....	26-6
Product Updates.....	26-6
Packaging.....	26-6
Corona Performance .....	26-7
Hi*Lite XL 25k SML Data .....	26-8
Hi*Lite XL 30k SML Data .....	26-9
Hi*Lite XL 50k SML Data .....	26-10
End Fitting Detail .....	26-11
Key to the Catalog Numbers .....	26-11

## Hi\*Lite® XL Insulators

Hi\*Lite XL suspension insulators in this publication embody the latest features available in polymer insulator design and manufacture.

From the early prototypes in 1971, through full scale introduction in 1976, and through the succeeding years, Hi\*Lite insulators have featured conservative design and high-quality manufacture.

Today's Hi\*Lite insulators will add to the over 1,000,000 already in service worldwide.

### Design

The structural design of the Hi\*Lite XL consists of these basic parts:

**Rod** - Hi\*Lite insulator fiberglass rod is produced from the highest quality materials. Strands are aligned for maximum tensile strength. The rod is more than 50 percent glass fibers in cross section.

**End Fittings** - End fittings are steel or ductile iron. They are crimped directly to the rod by a special process originated by Ohio Brass, and later adopted by many other producers. The crimp develops a high percentage of the rod's inherent tensile strength. It requires no inter-movement of the parts to achieve high strength, nor does it introduce potting compounds or adhesives.

**Weathersheds** - Weathersheds are high pressure injection molded by Ohio Brass, from the proprietary

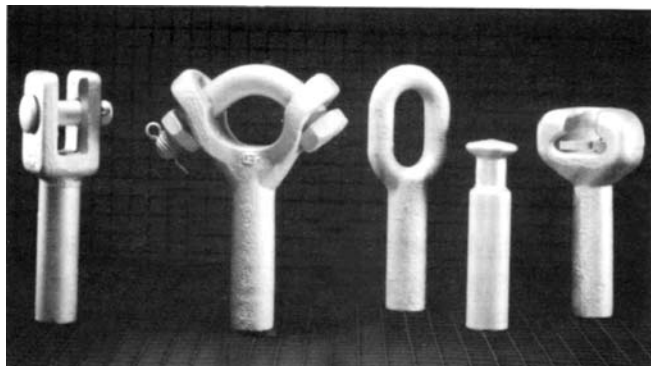

compound ESP™. Housings manufactured with ESP silicone alloy rubber exhibit hydrophobicity, high mechanical strength, high corona resistance and low permeability to moisture.

**Interface** - Hi\*Lite insulators use Ohio Brass' patented live silicone interface (U.S. Patent No. 3,898,372). This feature prevents intrusion of moisture and contaminating elements. If the exterior seal is damaged, redundant o-ring seals within the live silicone interface prohibit the lengthwise migration of intrusive elements between shed and rod.

### Leakage Distance

Hi\*Lite XL insulators feature high leakage distance for maximum resistance to contamination and leakage currents. Specific leakage distance (leakage divided by dry arcing distance) is higher than porcelain. Contact Ohio Brass if you have extra-high leakage distance needs.

### Washability

Hi\*Lite insulators listed in this catalog are suitable for flood washing up to 200 psi. The design incorporates positive, labyrinth seals to ensure long-term security against water entry. Conventional dry-particle, air-pressure cleaning methods may also be employed. A cleaning guideline is available from Ohio Brass.

If your washing requirements exceed flood washing, contact Ohio Brass.

### Mechanical Ratings

Hi\*Lite XL suspension insulators are rated and tested in accordance with ANSI Standard C29.11. Certified test reports in detail are available.

SML ratings are 25k, 30k and 50k pounds.

RTL ratings are consistent with the ANSI standard. Actual factory routine tests are conducted at loads equal to or greater than the RTL rating.

Markings for XL insulator designs are permanently embossed into the ground end corona shielding rings. Markings include SML and RTL, part number, assembly date code, and Ohio Brass identification.

### Lengths Available

Hi\*Lite suspension insulators are available in lengths appropriate for 69 kV through 765 kV. Longer lengths can be produced for special projects. Length increments are approximately three inches.

### Product Updates

Hi\*Lite XL insulator end fittings are attached with an improved crimping process using the successful principles of earlier Hi\*Lite designs. The corona shield has been refined; a more compact Corona Shielding Ring (CSR) provides both electrical stress relief and a mechanical seal at the housing-to-end fitting interface.

### Packaging

Hi\*Lite suspension insulators are packaged in appropriate quantities in wood crates. As an option, Ohio Brass offers packaging of the insulators in individual sleeves.

### Corona Performance

Hi\*Lite XL suspension insulators are RIV and corona free through 161 kV, by the use of integral Corona Shield Rings (CSR). Due to the small diameter of the end fittings, corona shielding is necessary at 230 kV and above. The table below details the rings necessary for voltages equal to or exceeding that listed in the column header.

#### Normal Applications: Top Grounded, Bottom Energized

Insulator	Orientation	230 kV Ring	345 kV Ring	500 kV Rings
Suspension 25/30 K SML	Top	NONE	NONE	2717613001
	Bottom	2717613001	2717053001	2717513001
Suspension 50 K SML	Top	NONE	NONE	2717613002
	Bottom	2717613002	2717053002	2717513002

**A**

The physical and electrical values for the insulators on pages 26-8 through 26-10 are shown without corona protection above 161 kV. Ohio Brass has therefore provided the table below that yields the physical and electrical changes to the insulator when rings are installed for voltages above 161 kV.

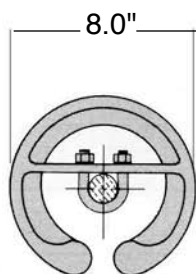

Part Number 271761

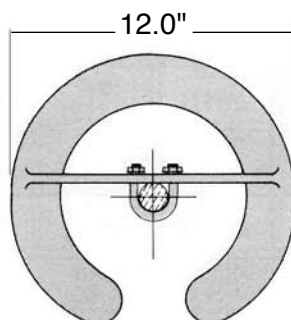

Part Number 271705

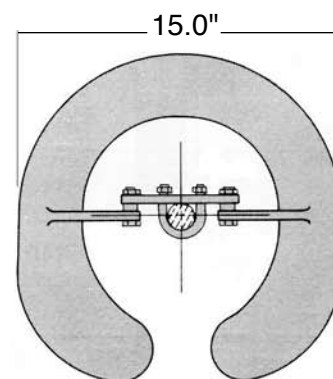

Part Number 271751

#### Physical & Electrical Change Table

Physical & Electrical Characteristics	230 kV Ring	345 kV Ring	500 kV Rings
Dry Arc Distance inches (mm)	-1.2 (-30.48)	-2 (-50.8)	-5 (-127.0)
Leakage Distance inches (mm)	0	0	0
60 Hz Flashover Dry - kV	-10	-15	-30
60 Hz Flashover Wet - kV	0	0	0
Critical Flashover Positive - kV	-15	-25	-65
Critical Flashover Negative - kV	-20	-30	-65
Net Weight pounds (kg)	3 (1.8)	3 (1.8)	5.1 (2.29)



**5/8" (16mm) Rod Diameter Suspension Insulators**

**Mechanical Ratings**  
**SML = 25,000 lbs. 111 kN**  
**RTL = 12,500 lbs. 56 kN**

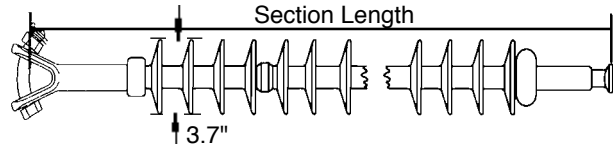

Selection Guide Typical Line Voltage, kV <sup>(1)</sup>						Catalog Number with Y-Clevis - 52.5 Ball	Section Length Inches (mm)	Number of Sheds	Dry Arc Distance inches (mm)	Leakage Distance inches (mm)	<sup>(2)</sup> 60 Flashover ANSI		<sup>(2)</sup> Critical Flashover ANSI		Net Weight pounds  (kg)
69	115	138	161	230	345						Dry-kV	Wet-kV	Pos-kV	Neg-kV	
						5110041201	34.7 (881)	16	24.7 (627)	61 (1549)	245	240	410	390	4.8 (2.2)
						5110051201	40.7 (1034)	20	30.7 (780)	76 (1930)	310	295	505	490	5.6 (2.5)
						5110061201	46.8 (1189)	24	36.8 (935)	92 (2337)	370	350	605	595	6.4 (2.9)
						5110071201	53.0 (1346)	28	42.9 (1090)	107 (2718)	430	405	700	695	7.1 (3.2)
						5110081201	59.1 (1501)	32	49.1 (1247)	122 (3099)	490	455	795	795	8.0 (3.6)
						5110091201	65.1 (1654)	36	55.1 (1397)	138 (3505)	545	505	890	890	8.8 (4.0)
						5110101201	71.3 (1811)	40	61.2 (1554)	152 (3861)	600	555	985	990	9.5 (4.3)
						5110111201	77.4 (1966)	44	67.4 (1712)	168 (4267)	655	605	1080	1090	10.4 (4.7)
						5110121201	83.5 (2121)	48	73.5 (1867)	184 (4674)	710	655	1170	1185	11.2 (5.1)
						5110131201	89.5 (2273)	52	79.5 (2019)	198 (5029)	760	700	1260	1280	11.9 (5.4)
						5110141201	95.7 (2431)	56	85.6 (2174)	214 (5436)	810	750	1350	1370	12.7 (5.8)
						5110151201	101.8 (2586)	60	91.7 (2329)	229 (5817)	855	790	1440	1465	13.5 (6.1)
						5110161201	108.0 (2743)	64	97.9 (2487)	245 (6223)	905	835	1530	1560	14.4 (6.5)
						5110171201	114.0 (2896)	68	103.9 (2639)	260 (6604)	945	880	1615	1650	15.2 (6.9)
						5110181201	120.1 (3051)	72	110.0 (2794)	275 (6985)	990	920	1705	1740	15.9 (7.2)
						5110191201	126.2 (3205)	76	116.2 (2951)	290 (7366)	1030	960	1790	1830	16.7 (7.6)

Notes: (1) For voltages above 345 kV, and other section lengths, contact Ohio Brass.  
 (2) Tests in accordance with ANSI C29.1-1982. Electrical values are without corona ring.  
 For voltages above 161 kV refer to Page 26-7 for Corona Rings, and associated physical/electrical changes to above data.  
 Dimensions are within allowable tolerances as specified in ANSI C29.11.

Ground Fitting	Line Fitting	Suffix Code	Length Change		Weight Change	
			Inches	mm	Pounds	kg
Eye	Ball	1001	-.06	-1.5	-2.5	-.11
Eye	Eye	1000	1.28	32.5	-2.5	-.11
Socket	Ball	1301	-.97	-24.6	-.05	-.01
Clevis	Ball	1401	-1.00	-25.4	-.15	-.07
Y-Clevis	Eye	1200	1.34	34.0	0	0
Clevis	Eye	1400	.34	8.6	-.15	-.007

For configurations not shown contact Ohio Brass.



## 5/8" (16mm) Rod Diameter Suspension Insulators

**Mechanical Ratings**  
**SML = 30,000 lbs. 133 kN**  
**RTL = 15,000 lbs. 67 kN**

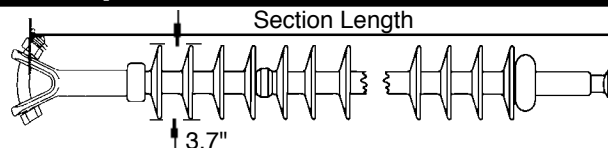

Selection Guide Typical Line Voltage, kV <sup>(1)</sup>						Catalog Number with Y-Clevis - 52.5 Ball	Section Length Inches (mm)	Number of Sheds	Dry Arc Distance inches (mm)	Leakage Distance inches (mm)	<sup>(2)</sup> 60 Flashover ANSI		<sup>(2)</sup> Critical Flashover ANSI		Net Weight pounds (kg)
											Dry-kV	Wet-kV	Pos-kV	Neg-kV	
69	115	138	161	230	345	5150041201	34.7 (881)	16	24.7 (627)	61 (1549)	245	240	410	390	4.8 (2.2)
						5150051201	40.7 (1034)	20	30.7 (780)	76 (1930)	310	295	505	490	5.6 (2.5)
						5150061201	46.8 (1189)	24	36.8 (935)	92 (2337)	370	350	605	595	6.4 (2.9)
						5150071201	53 (1346)	28	42.9 (1090)	107 (2718)	430	405	700	695	7.1 (3.2)
						5150081201	59.1 (1501)	32	49.1 (1247)	122 (3099)	490	455	795	795	8 (3.6)
						5150091201	65.1 (1654)	36	55.1 (1397)	138 (3505)	545	505	890	890	8.8 (4.0)
						5150101201	71.3 (1811)	40	61.2 (1554)	152 (3861)	600	555	985	990	9.5 (4.3)
						5150111201	77.4 (1966)	44	67.4 (1712)	168 (4267)	655	605	1080	1090	10.4 (4.7)
						5150121201	83.5 (2121)	48	73.5 (1867)	184 (4674)	710	655	1170	1185	11.2 (5.1)
						5150131201	89.5 (2273)	52	79.5 (2019)	198 (5029)	760	700	1260	1280	11.9 (5.4)
						5150141201	95.7 (2431)	56	85.6 (2174)	214 (5436)	810	750	1350	1370	12.7 (5.8)
						5150151201	101.8 (2586)	60	91.7 (2329)	229 (5817)	855	790	1440	1465	13.5 (6.1)
						5150161201	108 (2743)	64	97.9 (2487)	245 (6223)	905	835	1530	1560	14.4 (6.5)
						5150171201	114 (2896)	68	103.9 (2639)	260 (6604)	945	880	1615	1650	15.2 (6.9)
						5150181201	120.1 (3051)	72	110 (2794)	275 (6985)	990	920	1705	1740	15.9 (7.2)
						5150191201	126.2 (3205)	76	116.2 (2951)	290 (7366)	1030	960	1790	1830	16.7 (7.6)

A

Notes: (1) For voltages above 345 kV, and other section lengths, contact Ohio Brass.  
 (2) Tests in accordance with ANSI C29.1-1982. Electrical values are without corona ring.  
 For voltages above 161 kV refer to Page 26-7 for Corona Rings, and associated physical/electrical changes to above data.  
 Dimensions are within allowable tolerances as specified in ANSI C29.11.

**Y-Clevis Tower Attachment Detail  
for 25k, 30k, and 50k SML Insulators**

SML	"D" Max. Inches
25/30k	.531
50k	1.0

To achieve insulator SML value, proper grade steel should be used

Ground Fitting	Line Fitting	Suffix Code	Length Change		Weight Change	
			Inches	mm	Pounds	kg
Eye	Ball	1001	-0.06	-1.5	-2.50	-0.110
Eye	Eye	1000	1.28	32.5	-2.50	-0.110
Socket	Ball	1301	-0.97	-24.6	-0.05	-0.010
Clevis	Ball	1401	-1.00	-25.4	-0.15	-0.070
Y-Clevis	Eye	1200	1.34	34.0	0.00	0.000
Clevis	Eye	1400	0.34	8.6	-0.15	-0.007

For configurations not shown contact Ohio Brass.



## 7/8" (22mm) Rod Diameter Suspension Insulators

**Mechanical Ratings**  
**SML = 50,000 lbs. 222 kN**  
**RTL = 25,000 lbs. 111 kN**

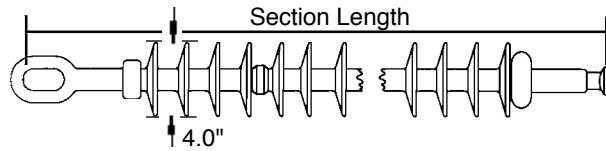

Selection Guide Typical Line Voltage, kV <sup>(1)</sup>						Catalog Number with Chain Eye - 52.11 Ball	Section Length Inches (mm)	Number of Sheds	Dry Arc Distance inches (mm)	Leakage Distance inches (mm)	<sup>(2)</sup> 60 Flashover ANSI		<sup>(2)</sup> Critical Flashover ANSI		Net Weight pounds  (kg)
											Dry-kV	Wet-kV	Pos-kV	Neg-kV	
115	138	161	230	345	500	5130071001	55.8 (1417)	28	42.9 (1090)	106 (2692)	430	400	700	695	12.7 (5.8)
						5130081001	62.0 (1574)	32	49.0 (1245)	121 (3073)	490	455	795	795	13.7 (6.2)
						5130091001	68.0 (1727)	36	55.0 (1397)	136 (3454)	545	505	890	890	14.8 (6.7)
						5130101001	74.1 (1882)	40	61.2 (1554)	151 (3835)	600	555	985	990	15.9 (7.2)
						5130111001	80.3 (2040)	44	67.3 (1709)	167 (4242)	655	605	1080	1090	16.9 (7.7)
						5130131001	92.4 (2347)	52	79.5 (2019)	197 (5004)	760	700	1260	1280	19.1 (8.7)
						5130141001	98.5 (2502)	56	85.6 (2174)	212 (5385)	810	745	1350	1370	20.2 (9.2)
						5130151001	104.7 (2659)	60	91.7 (2329)	228 (5791)	855	790	1440	1465	21.2 (9.6)
						5130171001	116.8 (2967)	68	103.9 (2639)	258 (6553)	945	875	1615	1650	24.4 (11.1)
						5130181001	123.0 (3124)	72	110.0 (2794)	273 (6934)	990	915	1705	1740	24.5 (11.1)
						5130191001	129.1 (3279)	76	116.2 (2951)	288 (7315)	1030	955	1790	1830	25.5 (11.6)
						5130211001	141.2 (3586)	84	128.3 (3259)	319 (8103)	1110	1035	1960	2005	27.6 (12.5)
						5130231001	153.5 (3899)	92	140.6 (3271)	349 (8885)	1180	1105	2125	2175	29.8 (13.5)
						5130251001	165.7 (4209)	100	152.7 (3879)	379 (9627)	1245	1175	2285	2345	31.9 (14.5)
						5130271001	177.9 (4519)	108	165.0 (4191)	410 (10414)	1305	1240	2445	2510	34.0 (15.4)
						5130281001	184.1 (4676)	112	171.1 (4346)	425 (10795)	1330	1270	2520	2590	35.1 (15.9)

Notes: (1) For voltages above 500 kV, and other section lengths, contact Ohio Brass.  
 (2) Tests in accordance with ANSI C29.1-1982. Electrical values are without corona ring.  
 For voltages above 161 kV refer to Page 26-7 for Corona Rings, and associated physical/electrical changes to above data.  
 Dimensions are within allowable tolerances as specified in ANSI C29.11.

### End Fitting Example

You need the electrical and mechanical characteristics of Catalog #5130101001. But, a Y-clevis is needed at the ground end instead of an eye. From the table at the right, find the code for the Y-clevis/ball configuration 1201. You should order Catalog #5130101201. The same process is used for 5/8" (25k) and 7/8" (30k) insulators.

Ground Fitting	Line Fitting	Suffix Code	Length Change		Weight Change	
			Inches	mm	Pounds	kg
Y-Clevis	Ball	1201	-.58	-14.7	.4	.18
Eye	Eye	1000	1.26	32.0	-.4	-.18
Socket	Ball	1301	-.72	-18.3	.4	.18
Y-Clevis	Eye	1200	-.58	-14.7	0	0

For configurations not shown contact Ohio Brass.

### Most Common End Fittings

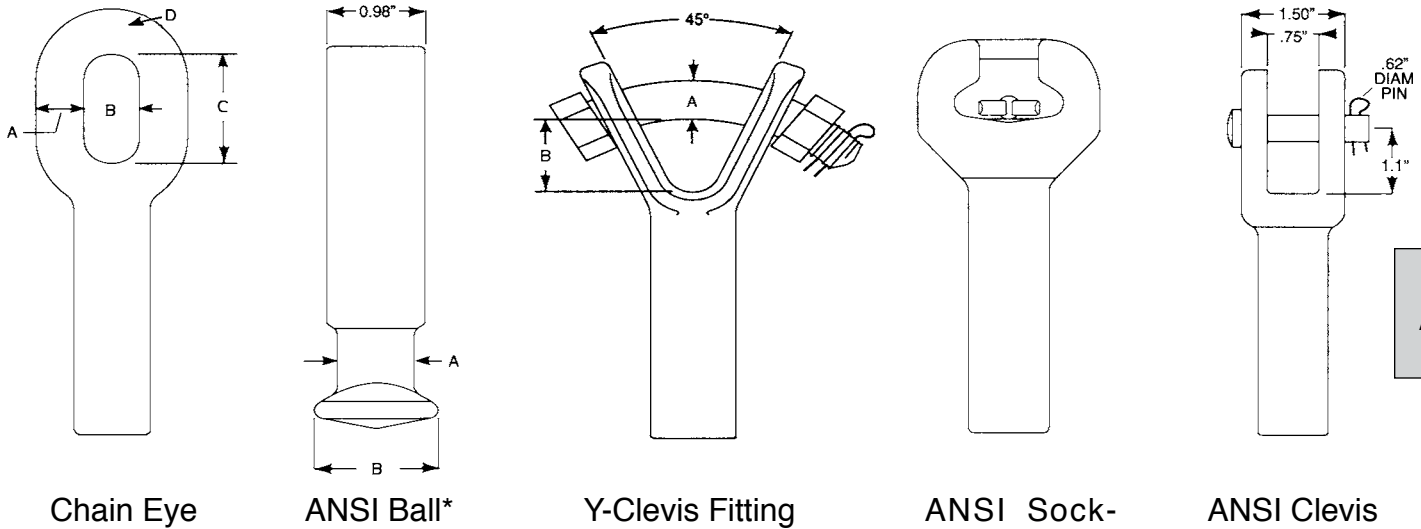

FITTING TYPE	SML k-LB (kN)	ANSI CLASS	DIMENSIONS IN. (mm)			
			A	B	C	D
CHAIN EYE	25 (111) - 30 (133)	-	0.62	1.00	2.00	0.62
	50 (222)	-	0.75	1.00	2.00	0.85
BALL & SOCKET	25 (111) - 30 (133)	52-5	0.73	1.29	-	-
	50 (222)	52-11	0.92	1.63	-	-
Y-CLEVIS	25 (111) - 30 (133)	-	0.75	1.53	-	-
	50 (222)	-	0.88	1.59	-	-
CLEVIS	25 (111) - 30 (133)	52-6	0.62	0.75	1.50	1.10

\* For IEC 16mm and 20mm Ball and Socket fittings, contact Ohio Brass.

### Hi\*Lite XL Suspension Insulators: Key to the Catalog Numbers

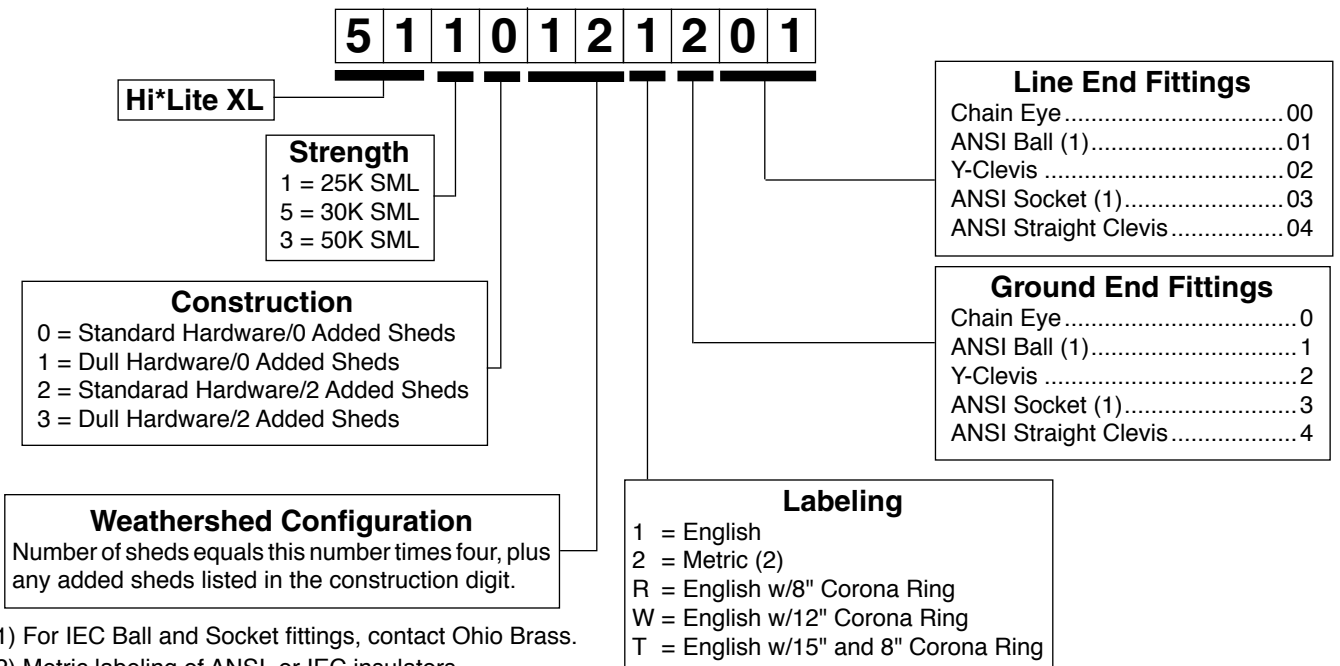

(1) For IEC Ball and Socket fittings, contact Ohio Brass.  
(2) Metric labeling of ANSI, or IEC insulators.



# Hi\*Lite® XL Line Post Insulators

**B**

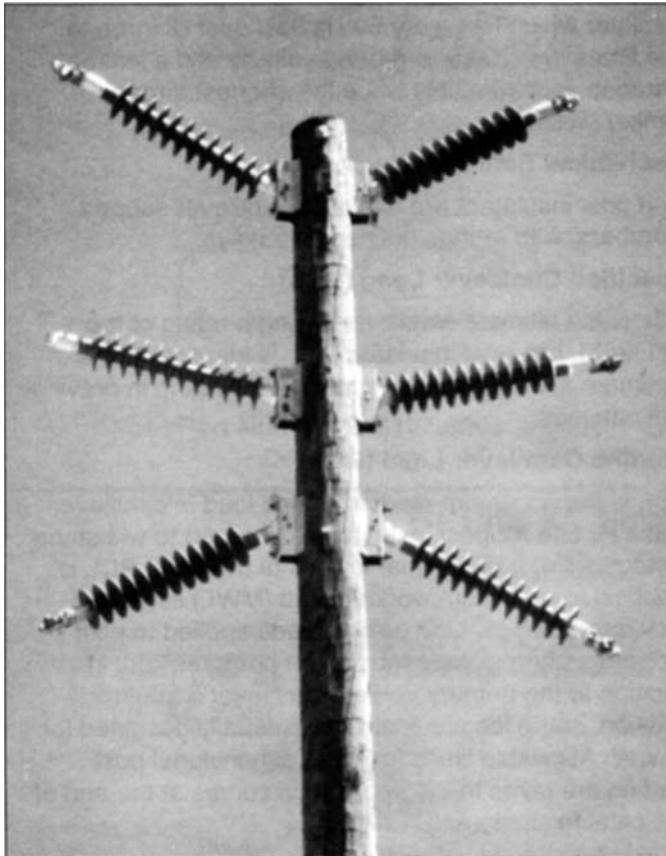

## Table of Contents

	Page
Design .....	26-14
Rod .....	26-14
End Fittings.....	26-14
Weathersheds .....	26-14
Interface.....	26-14
Leakage Distance.....	26-14
Washability .....	26-14
Mechanical Ratings .....	26-14
Corona Rings.....	26-15
Packaging.....	26-15
Key to 2.5" Catalog Numbers .....	26-15
Hi*Lite XL 2.5" Rod Horizontal Line Posts.....	26-16
Hi*Lite XL 2.5" Rod Vertical Line Posts .....	26-17
Hi*Lite XL 2.5" Rod Vertical Line Post Assembly.....	26-18
Hi*Lite XL 2.5" Rod Base Fittings .....	26-19
Hi*Lite XL 2.5" Rod Line Fittings .....	26-20
Hi*Lite XL 3.0" Rod Horizontal Line Posts.....	26-21
Key to 3.0" Catalog Numbers .....	26-21
Hi*Lite II 3.0" Rod Horizontal Line Posts .....	26-22
Hi*Lite II 3.0" Rod Vertical Line Posts .....	26-23
Hi*Lite XL 3.0" Rod. Dia. Base Fittings.....	26-24
Hi*Lite XL 3.0" Rod. Dia. Line Fittings .....	26-25
Clamps and Assemblies .....	26-26



## Hi\*Lite\*® XL Insulators

Hi\*Lite XL line post insulators in this publication embody the latest features available in polymer insulator design and manufacture.

From the early prototypes in 1971, through full scale introduction in 1976, and through the succeeding years, Hi\*Lite insulators have featured conservative design and high-quality manufacture.

Today's Hi\*Lite insulators will add to the over 1,000,000 already in service worldwide.

### Design

The structural design of the Hi\*Lite XL consists of these basic parts:

**Rod** - Hi\*Lite insulator fiberglass rod is produced from the highest quality materials. Strands are aligned for maximum tensile strength. The rod is more than 50 percent glass fibers in cross section.

**End Fittings** - End fittings are aluminum or ductile iron. They are crimped directly to the rod by a special process originated by Ohio Brass, and later adopted by many other producers. The crimp requires no intermovement of the parts to achieve high strength, nor does it introduce potting compounds or adhesives.

**Weathersheds** - Weathersheds are high pressure injection molded by Ohio Brass, from the proprietary compound ESP™. Housings manufactured with ESP silicone alloy rubber exhibit hydrophobicity, high mechanical strength, high corona resistance and low permeability to moisture.

**Interface** - Hi\*Lite insulators use Ohio Brass' patented live silicone interface (U.S. Patent No. 3,898,372). This feature prevents intrusion of moisture and contaminating elements. If the exterior seal is damaged, redundant o-ring seals within the live silicone interface prohibit the lengthwise migration of intrusive elements between shed and rod.

### Leakage Distance

Hi\*Lite XL insulators feature high leakage distance for maximum resistance to contamination and leakage currents.

### Washability

Hi\*Lite Line Post insulators listed in this catalog are suitable for flood washing up to 200 psi. The design incorporates positive, labyrinth seals to ensure long-term security against water entry. Conventional dry-particle, air-pressure cleaning methods may also be employed. A cleaning guideline is available from Ohio Brass.

If your washing requirements exceed flood washing, contact Ohio Brass.

### Mechanical Ratings

Line post insulators are basically cantilever support members, with ratings defined as follows:

#### Specified Cantilever Load (SCL)

SCL is the ultimate cantilever strength rating of the Hi\*Lite XL line post insulator. SCL is identical to the minimum average breaking load (ABL) rating in previous catalogs.

#### Reference Cantilever Load (RCL)

RCL is the maximum recommended load in cantilever that a Hi\*Lite XL post insulator is designed to withstand during its life, and is equal to 50% of the SCL. RCL is identical to maximum working load (MWL) listed in previous catalogs. Line design loads applied to post insulators often include tension, or compression, in addition to the primary vertical cantilever load. In addition, some longitudinal load is usually designed for as well.

#### Combined Load

Contact your Hubbell Power Systems representative for combined load applications.

## 2.5" (63.5mm) Rod Diameter Horizontal Line Posts

### Corona Rings

Hi\*Lite XL line post insulators are corona free through 161 kV.

Application	161 kV & below	230 kV	345 kV
Line End Energized	Top - NONE Bott - NONE	Top - 2721273001 Bott - NONE	Top - 2721273001 Bott - NONE
Bottom End Energized	Top - NONE Bott - NONE	Top - NONE Bott - 2721273001	Top - NONE Bott - 2721273001

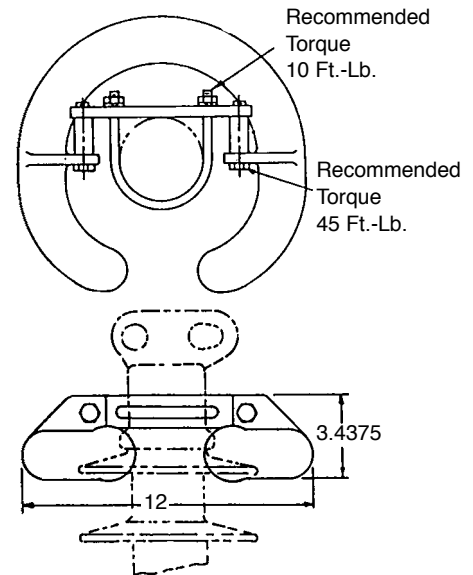

**Part Number 2721273001  
Control Ring**

B

### Packaging

Hi\*Lite XL line post insulators are packaged in appropriate quantities in open wood crates. As an option, Ohio Brass offers packaging of the insulators in individual sleeves.

### Hi\*Lite XL Line Post Insulators: Key to the Catalog Numbers

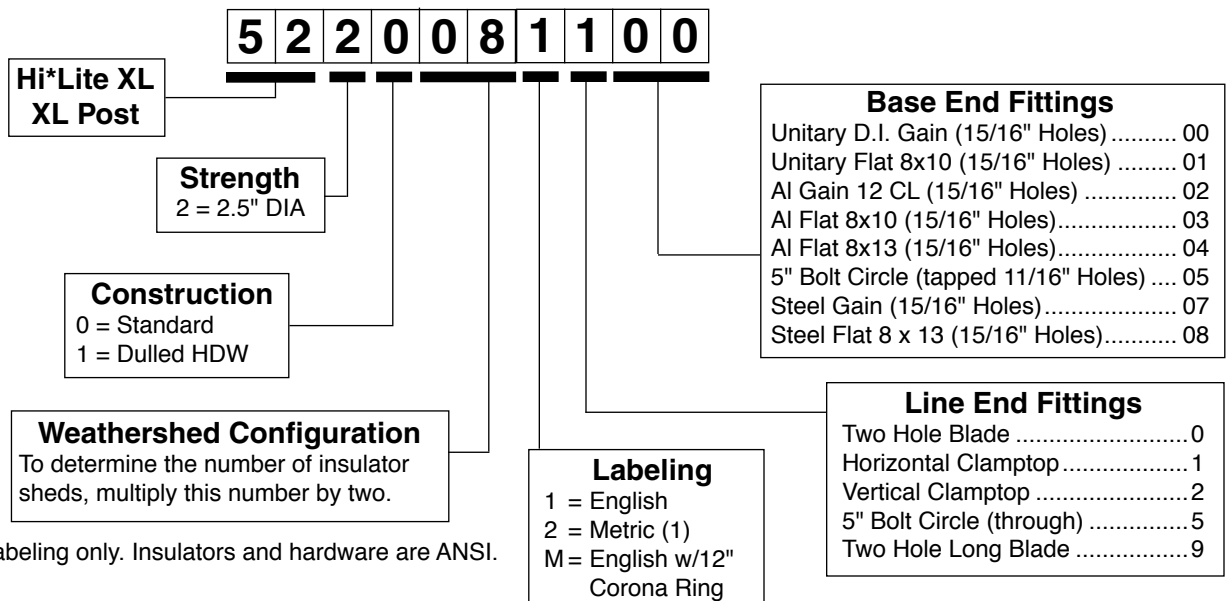

(1) Metric labeling only. Insulators and hardware are ANSI.

## 2.5" (63.5mm) Rod Diameter Horizontal Line Posts

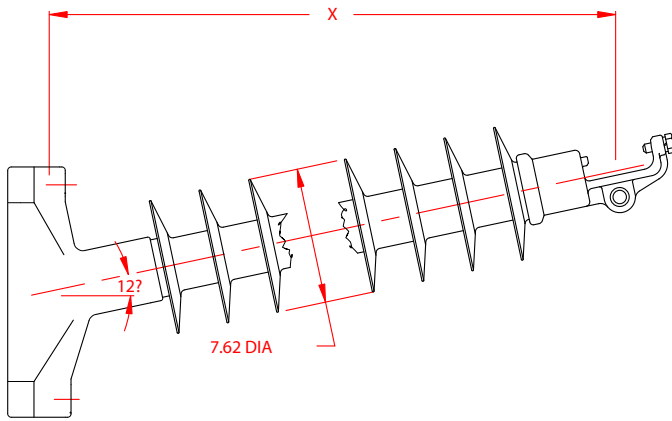

Line & Base Detail see pages 26-19 & 26-20

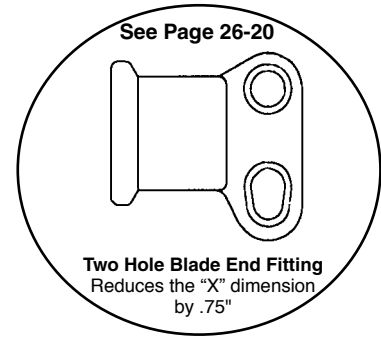

**Clamptop:**

Maximum Design Tension = 2,500 lb (11.1 kN)

**Two-Hole Blade:**

Maximum Design Tension = 7,500 lb. (33.4 kN)

Selection Guide Typical Line Voltage, kV						Catalog # with Gain Base & Clamptop End Fittings	"X" Length Inches (mm)	No. of Sheds	Dry Arc Distance inches (mm)	Leakage Distance inches (mm)	<sup>(1)</sup> 60 Flashover ANSI		<sup>(1)</sup> Critical Flashover ANSI		RCL pounds (kN)	Net Weight pounds (kg)
											Dry-kV	Wet-kV	Pos-kV	Neg-kV		
69	115	138	161	230	345	5220041102	33.5 (851)	8	23 (584)	54 (1372)	215	195	340	455	2500 (11.1)	47 (21.3)
						5220051102	38.6 (980)	10	28 (711)	68 (1727)	270	245	420	535	2500 (11.1)	50 (22.7)
						5220061102	43.9 (1115)	12	33 (838)	82 (2083)	325	295	505	620	2135 (9.5)	54 (24.5)
						5220071102	49.2 (1250)	14	39 (991)	96 (2438)	385	340	590	705	1865 (8.3)	57 (25.9)
						5220081102	54.5 (1384)	16	44 (1118)	110 (2794)	440	385	675	785	1650 (7.3)	61 (27.7)
						5220091102	59.6 (1514)	18	49 (1245)	124 (3150)	490	430	760	865	1490 (6.6)	65 (29.5)
						5220101102	64.8 (1646)	20	55 (1397)	138 (3505)	545	475	845	950	1350 (6.0)	68 (30.9)
						5220111102	70.1 (1781)	22	60 (1524)	152 (3861)	600	520	930	1035	1235 (5.5)	72 (32.7)
						5220121102	75.4 (1915)	24	65 (1651)	166 (4216)	650	560	1015	1115	1140 (5.0)	75 (34.1)
						5220131102	80.5 (2045)	26	71 (1803)	180 (4572)	700	600	1095	1195	1060 (4.7)	79 (35.9)
						5220141102	85.8 (2180)	28	76 (1930)	194 (4928)	755	635	1180	1280	990 (4.4)	82 (37.2)
						5220151102	91.1 (2314)	30	81 (2057)	208 (5283)	805	675	1265	1365	925 (4.1)	86 (39.0)
						5220161102	96.3 (2446)	32	87 (2210)	222 (5639)	855	710	1350	1445	870 (3.6)	89 (40.4)
						5220171102	101.4 (2575)	34	92 (2337)	236 (5994)	905	745	1435	1525	820 (3.6)	93 (42.2)
						5220181102	106.7 (2710)	36	97 (2464)	250 (6350)	955	780	1520	1610	780 (3.5)	97 (44.0)
						5220191102	112.0 (2845)	38	103 (2616)	264 (6706)	1005	810	1605	1695	740 (3.3)	100 (45.4)

Notes: (1) Tests in accordance with ANSI C29.1-1982. Electrical values are without corona ring.  
 (2) RCL is the maximum continuous load at which the post should be applied.  
 For voltages above 161 kV refer to Page 26-15 for Corona Rings.  
 Dimensions are within allowable tolerances as specified in ANSI C29.11.



## 2.5" (63.5mm) Rod Diameter Vertical Line Posts

**Maximum Design Tension**  
2,500 lb (11.1 kN)

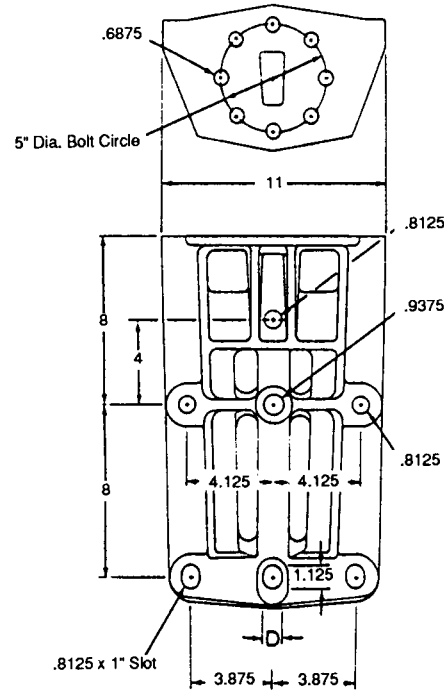
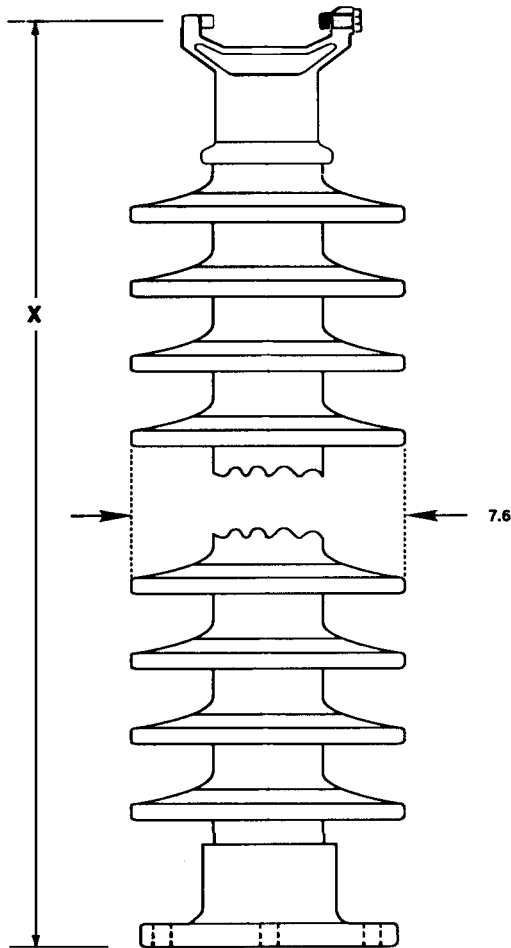

Aluminum Alloy  
A356-T6

Catalog No. 75115  
134,400 In.-Lb. Rating

Line & Base Fitting Detail see pages 26-19 & 26-20

Selection Guide Typical Line Voltage, kV				Catalog # with 5" Bolt Circle & Vert. Clamtop <sup>(3)</sup>	"X" Length Inches (mm)	No. of Sheds	Dry Arc Distance inches (mm)	Leakage Distance inches (mm)	<sup>(1)</sup> 60 Flashover ANSI		<sup>(1)</sup> Critical Flashover ANSI		RCL pounds (kN)	Net Weight pounds (kg)
69	115	138	161						Dry-kV	Wet-kV	Pos-kV	Neg-kV		
				5220041205	30.7 (780)	8	23 (584)	54 (1371)	215	195	340	455	2500 (11.1)	27 (12.3)
				5220051205	35.9 (912)	10	28 (711)	68 (1727)	270	245	420	535	2475 (11.0)	30 (13.6)
				5220061205	41.3 (1049)	12	33 (838)	82 (2083)	325	295	505	620	2115 (9.4)	34 (15.4)
				5220071205	46.7 (1186)	14	39 (991)	96 (2438)	385	340	590	705	1850 (8.2)	37 (16.8)
				5220081205	52.1 (1323)	16	44 (1118)	110 (2734)	440	385	675	785	1640 (7.3)	41 (18.6)
				5220091205	57.4 (1458)	18	49 (1245)	124 (3150)	490	430	760	865	1480 (6.6)	45 (20.4)

Notes: (1) Tests in accordance with ANSI C29.1-1982.

(2) RCL is the maximum cantilever continuous load at which the post should be applied.

(3) Mounting Base Catalog No. 75115 may be ordered with these Catalog numbers for a vertical assembly.

## 2.5" (63.5mm) Rod Diameter Vertical Line Post Assembly

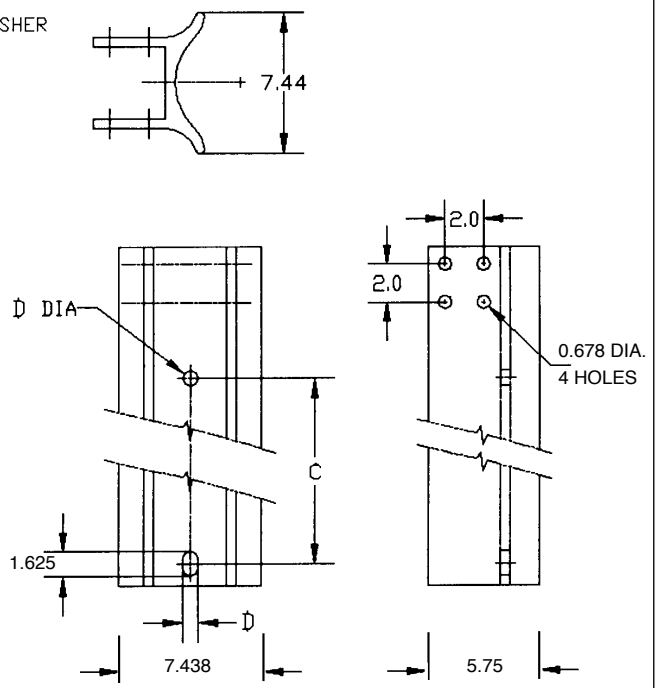
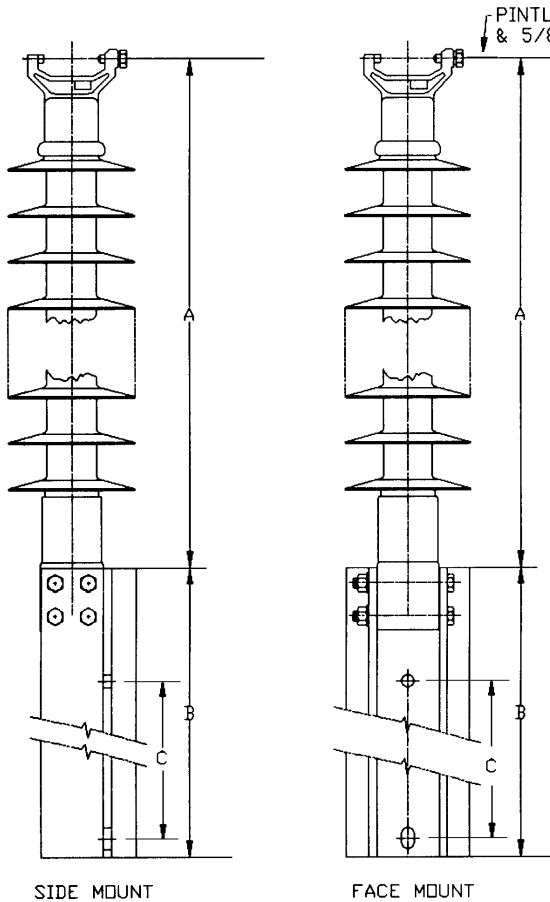

Aluminum Alloy  
6063-T5  
Base Detail

**To Order an Assembly -** Pick an insulator from Table A based on your Electrical and Mechanical needs — next, select a Base configuration from Table B, for your mounting position needs.

Line End Fitting Detail see pages 26-19 & 26-20

Selection Guide Typical Line Voltage, kV				(1)Catalog # with Vertical Clamptop & Base Code	"A" Length Inches (mm)
69	115	138	161		
				52200412XX	30.4 (772)
				52200512XX	35.6 (904)
				52200612XX	41.0 (1041)
				52200712XX	46.4 (1179)
				52200812XX	51.8 (1316)
				52200912XX	57.0 (1448)

(1) Insulators in Table A have the same electrical and mechanical characteristics as those on Page 26-17 with Code 1205.

Table A

"XX" Code	Style	"B" Length Inches (mm)	"C" Length Inches (mm)	"D" Diameter Inches (mm)
20	Face	20 (508)	12 (305)	.8125 (21)
21	Side	20 (508)	12 (305)	.8125 (21)
22	Face	20 (508)	12 (305)	.9375 (24)
23	Side	20 (508)	12 (305)	.9375 (24)
24	Face	31.75 (806)	16 (406)	.8125 (21)
25	Side	31.75 (806)	16 (406)	.8125 (21)
26	Face	31.75 (806)	16 (406)	.9375 (24)
27	Side	31.75 (806)	16 (406)	.9375 (24)

Table B

## 2.5" (63.5 mm) Rod Diameter Base Fittings

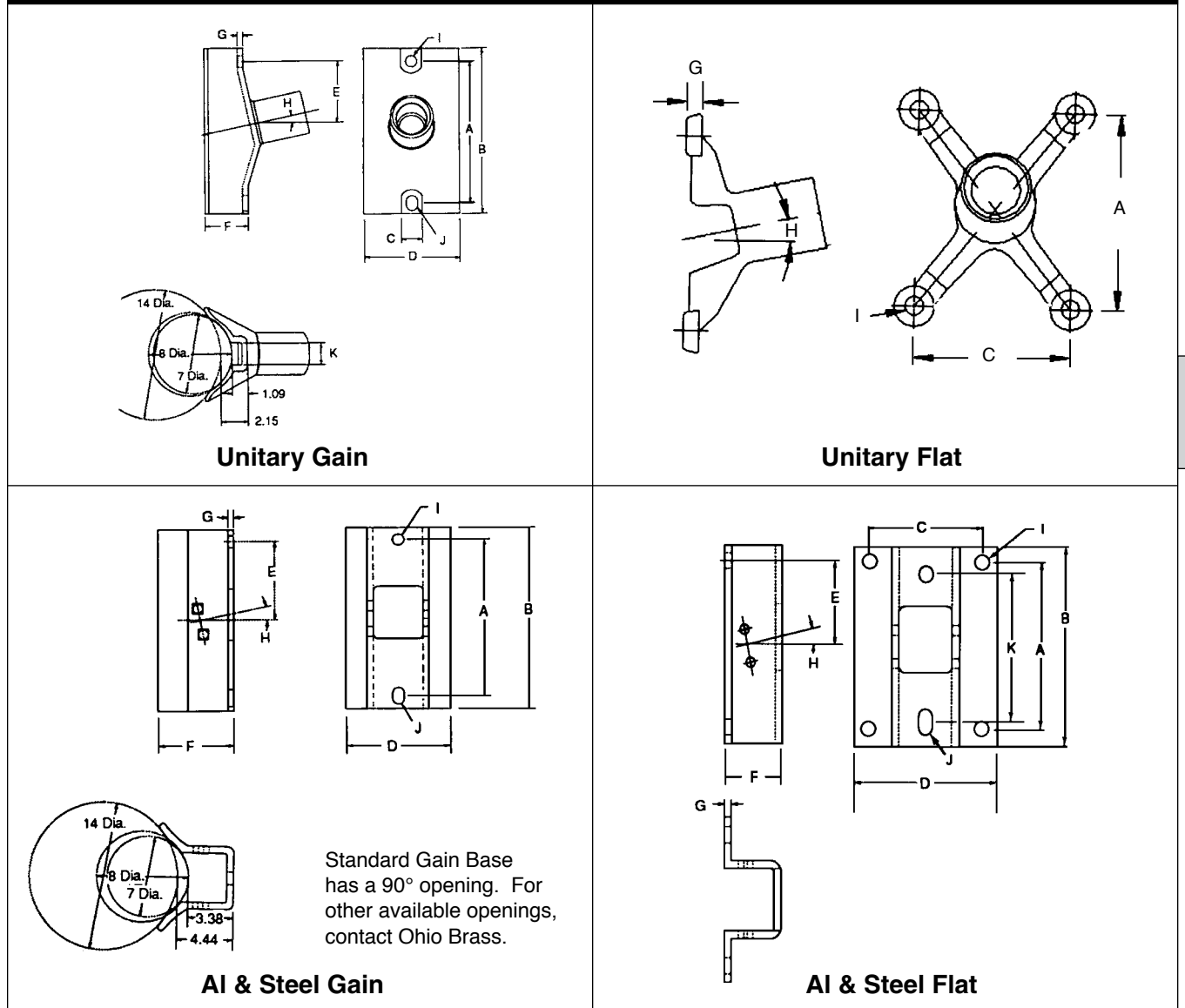

### Horizontal & Vertical Bases Dimensions (in inches)

Type (Code)*	A	B	C	D	E	F	G	H	I	J	K	Material
Unitary D.I. Gain (00)	12.0	14.0	1.75	8.06	-	3.54	0.5	12°	0.94	0.94 x 1.31	1.90	60-45-12 D.I.
Unitary D.I. Flat (01)	10.0	12.2	8.0	10.0	5.0	-	0.8	12°	0.94	-	-	60-45-12 D.I.
5" B.C. (15)	4.75	6.25	3.63	0.90	5.0	-	-	-	0.69	-	-	60-45-12 D.I.
5" B.C. (05)	4.75	6.25	3.63	0.90	5.0	-	-	-	5/8 - 11 UFS	-	-	60-45-12 D.I.
Al Gain (02)	12.0	14.0	-	8.06	6.13	5.56	0.5	12°	0.94	0.94 x 1.31	-	6063 T5 Al
Al Gain (12)	12.0	14.0	-	8.06	6.13	5.56	0.5	12°	0.81	0.94 x 1.31	-	6063 T5 Al
Steel Gain (07)	12.0	15.0	-	8.33	6.5	6.04	0.38	12°	0.94	0.94 x 2.0	-	Low Carbon Steel
Al Flat (03)	10.0	12.0	8.0	10.0	5.0	4.0	0.5	12°	0.94	-	-	6063 T5 Al
Al Flat (13)	10.0	12.0	8.0	10.0	5.0	4.0	0.5	12°	0.81	-	-	6063 T5 Al
Steel Flat (08)	13.0	15.0	8.0	10.0	6.5	4.0	0.5	12°	1.125 x 0.94	0.94 x 2	12.0	Low Carbon Steel
Al Flat (04)	13.0	15.0	8.0	10.0	6.5	4.0	0.5	12°	0.94	0.94 x 1.31	12.0	6063 T5 Al
Al Flat (14)	13.0	15.0	8.0	10.0	6.5	4.0	0.5	12°	0.81	0.81 x 1.31	12.0	6063 T5 Al

\*Code is the third and fourth numbers in the Suffix Code of the Catalog Number.

## 2.5" (63.5 mm) Rod Diameter Line Fittings

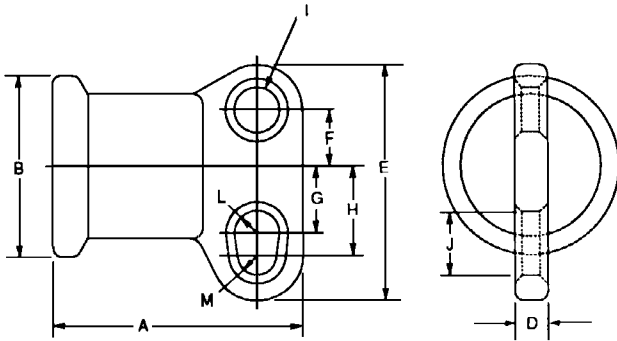

Transverse Compressing Swing Angle for Conductor Suspension Clamp	
2 Hole Blade (Std.)	2 Hole Long Blade
40 deg. max.	64 deg. max.

**Two Hole Blade**  
\*12° upsweep post angles

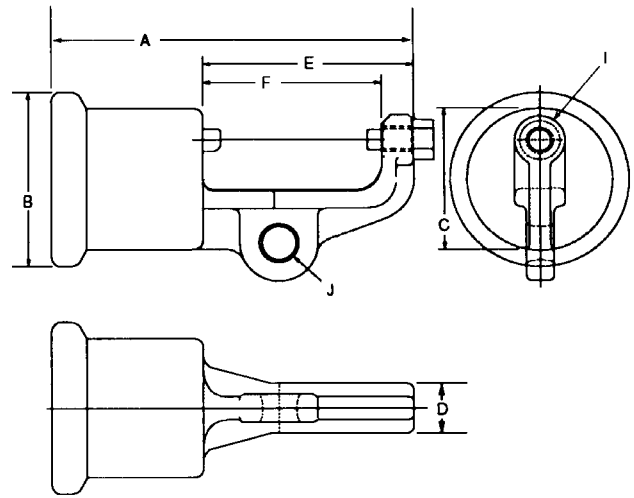

**Horizontal Clamptop**

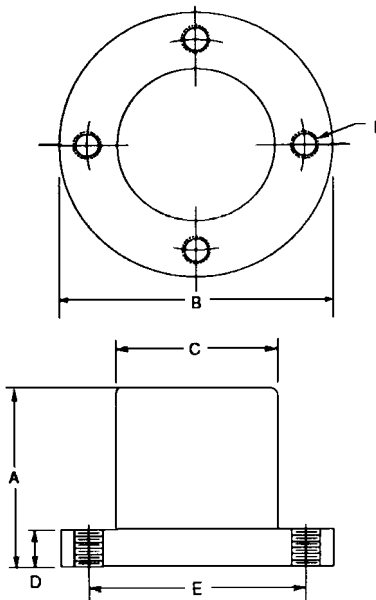

**5" Bolt Circle**  
Line or Base Fitting

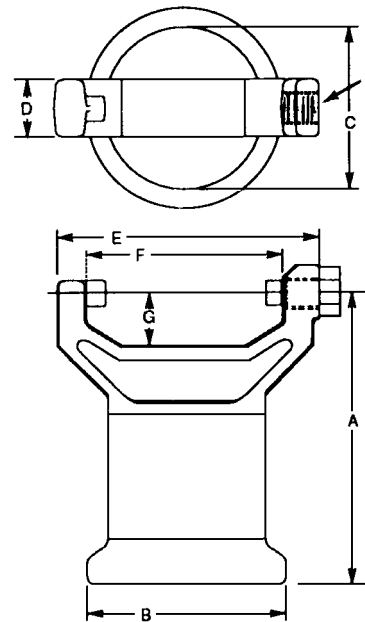

**Vertical Clamptop**  
Part per ANSI C29.7

### Horizontal & Vertical End Fittings Dimensions (in inches)

Type (Code)*	A	B	C	D	E	F	G	H	I	J	L	M	Material
2 Hole Blade (0)	5.73	4.0	-	0.75	5.25	1.25	1.50	2.00	1.0	1.44	0.5R	0.44 R	60-40-18 D.I.
2 Hole Long Blade (9)	5.73	4.0	-	0.75	7.75	1.25	4.0	4.5	1.0	1.44	0.5R	0.44R	60-40-18 D.I.
H. Clamptop (1)	8.24	4.0	3.30	1.12	4.72	4.0	-	-	5/8 - 11 UFS	0.75	-	-	60-40-18 D.I.
5" B.C. (3)	4.75	6.25	3.63	0.90	5.0	-	-	-	5/8 - 11 UFS	-	-	-	60-45-12 D.I.
5" B.C. (5)	4.75	6.25	3.63	0.90	5.0	-	-	-	0.69 x Holes	-	-	-	60-45-12 D.I.
V. Clamptop (2)	5.88	4.0	3.30	1.12	5.37	4.0	1.06	-	5/8 - 11 UFS	-	-	-	60-40-18 D.I.

\*Code is the 2nd number in the Suffix Code of the Catalog Number.

## 3.0" (76.2 mm) Rod Diameter Line Posts

### Corona Rings

Hi\*Lite XL line post insulators are corona-free through 230 kV line-to-ground.

Application	138/161 kV	230 kV	345 kV
Line End Energized	Top - NONE Bott. - NONE	Top - NONE Bott. - NONE	Top - 2737743001 Bott. - NONE

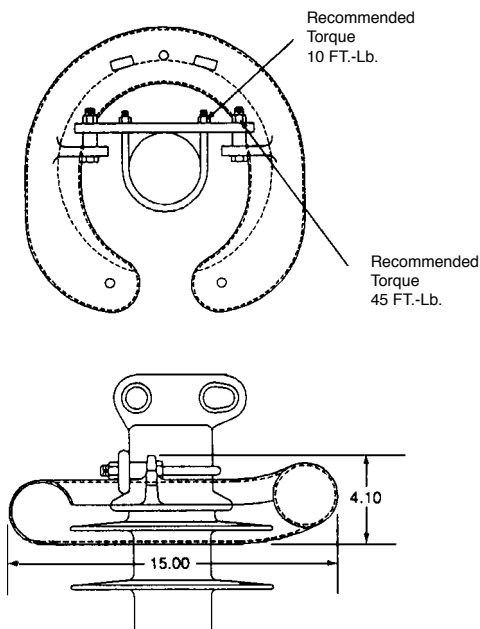

**Part Number 2737743001  
Control Ring**

B

### Hi\*Lite XL Line Post Insulators: Key to the Catalog Numbers

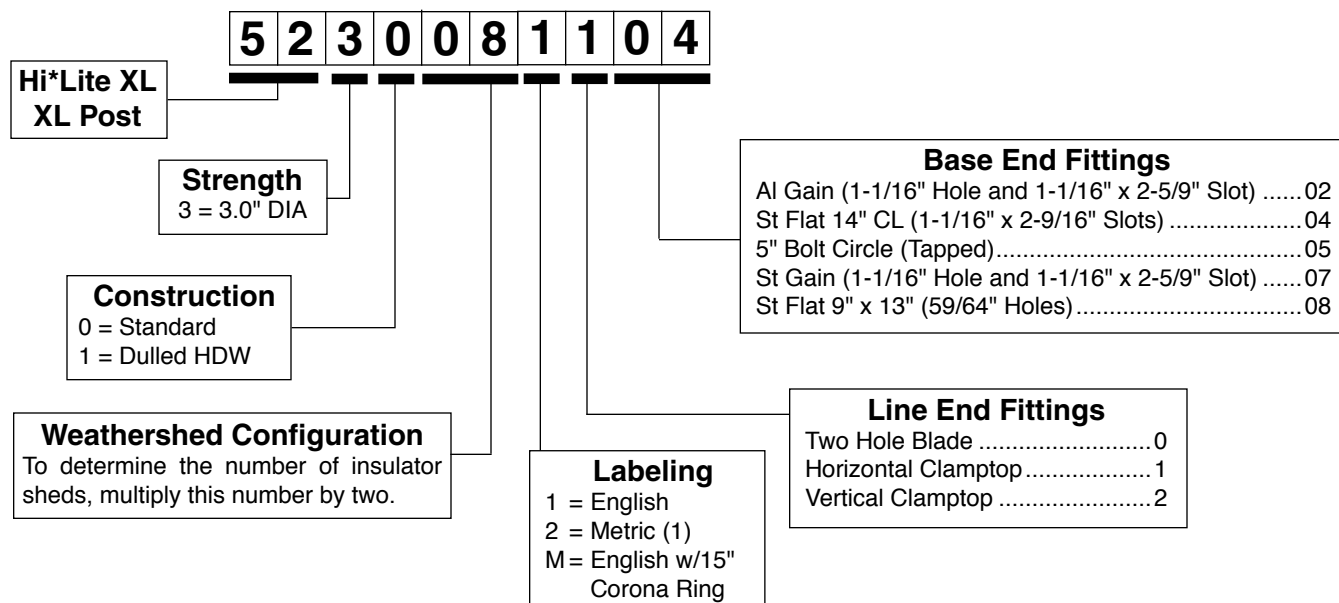

(1) Metric labeling only. Insulators and hardware are ANSI.

### 3.0" (76.2mm) Rod Diameter Horizontal Line Posts

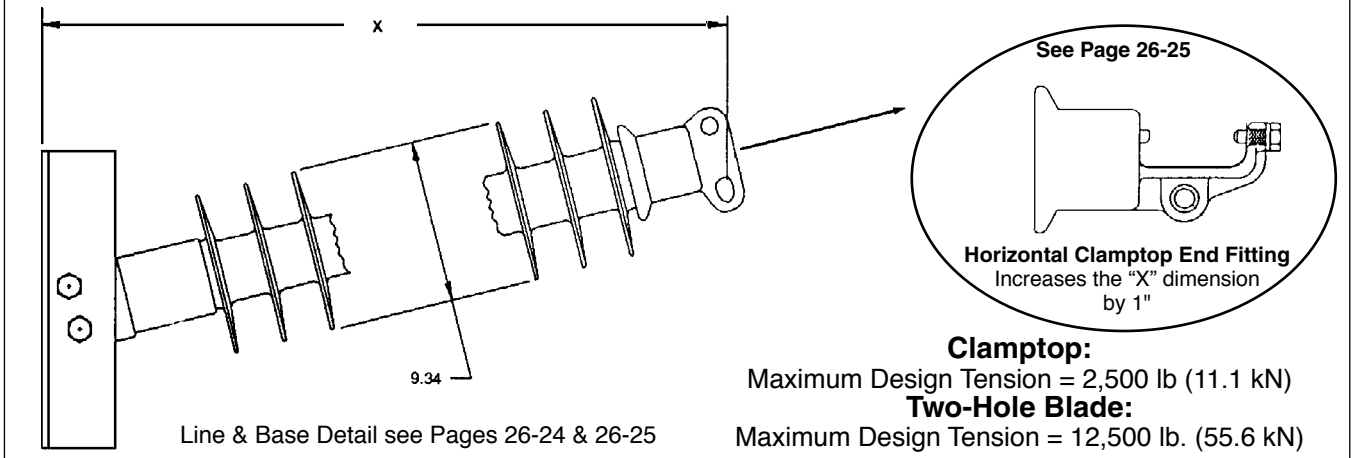

Selection Guide Typical Line Voltage, kV						Catalog # with Flat Base & Two Hole Blade	"X" Length Inches (mm)	No. of Sheds	Dry Arc Distance inches (mm)	Leakage Distance inches (mm)	<sup>(1)</sup> 60 Flashover ANSI		<sup>(1)</sup> Critical Flashover ANSI		<sup>(2)</sup> RCL pounds (kN)	Net Weight pounds (kg)
69	115	138	161	230	345						Dry-kV	Wet-kV	Pos-kV	Neg-kV		
						5230051004	38.8 (986)	10	29 (737)	77 (1956)	295	250	445	540	4405 (19.6)	90 (40.8)
						5230061004	43.8 (1113)	12	34 (864)	93 (2362)	345	295	530	620	3780 (16.8)	95 (43.1)
						5230071004	49.0 (1245)	14	39 (991)	108 (2743)	395	335	615	705	3295 (14.7)	100 (40.9)
						5230081004	54.8 (1392)	16	45 (1143)	124 (3150)	445	380	695	790	2920 (13.0)	106 (48.1)
						5230091004	59.3 (1506)	18	50 (1270)	140 (3556)	495	420	780	870	2620 (11.7)	110 (49.9)
						5230101004	64.5 (1638)	20	55 (1397)	156 (3962)	545	465	865	955	2380 (10.6)	115 (52.2)
						5230111004	69.5 (1765)	22	60 (1524)	171 (4343)	590	505	950	1035	2185 (9.7)	120 (54.4)
						5230121004	74.7 (1897)	24	66 (1676)	187 (4750)	640	550	1035	1120	2015 (9.0)	125 (56.7)
						5230131004	79.9 (2029)	26	71 (1803)	203 (5156)	685	590	1120	1200	1865 (8.3)	130 (58.9)
						5230141004	85.0 (2159)	28	76 (1930)	218 (5537)	735	640	1205	1285	1740 (7.7)	135 (61.2)
						5230151004	90.2 (2291)	30	82 (2083)	234 (5944)	780	670	1290	1365	1630 (7.2)	141 (63.9)
						5230161004	95.2 (2418)	32	87 (2210)	250 (6350)	825	710	1370	1445	1535 (6.8)	146 (66.2)
						5230171004	100.4 (2550)	34	92 (2337)	265 (6731)	870	755	1455	1530	1450 (6.5)	151 (68.5)
						5230181004	105.5 (2680)	36	98 (2489)	281 (7137)	915	795	1540	1615	1370 (6.1)	156 (70.8)
						5230191004	110.7 (2812)	38	103 (2616)	297 (7544)	960	835	1625	1695	1300 (5.8)	161 (73.1)
						5230201004	115.9 (2944)	40	108 (2743)	313 (7950)	1000	875	1710	1780	1240 (5.5)	166 (75.3)

Notes: (1) Tests in accordance with ANSI C29.1-1982. Electrical values are without corona ring.  
 (2) RCL is the maximum continuous load at which the post should be applied.  
 For voltages above 230 kV refer to Page 26-21 for Corona Rings. Electrical values are shown for insulators without rings. For electricals with rings, contact Ohio Brass.

## 3.0" (76.2 mm) Rod Diameter Vertical Line Posts

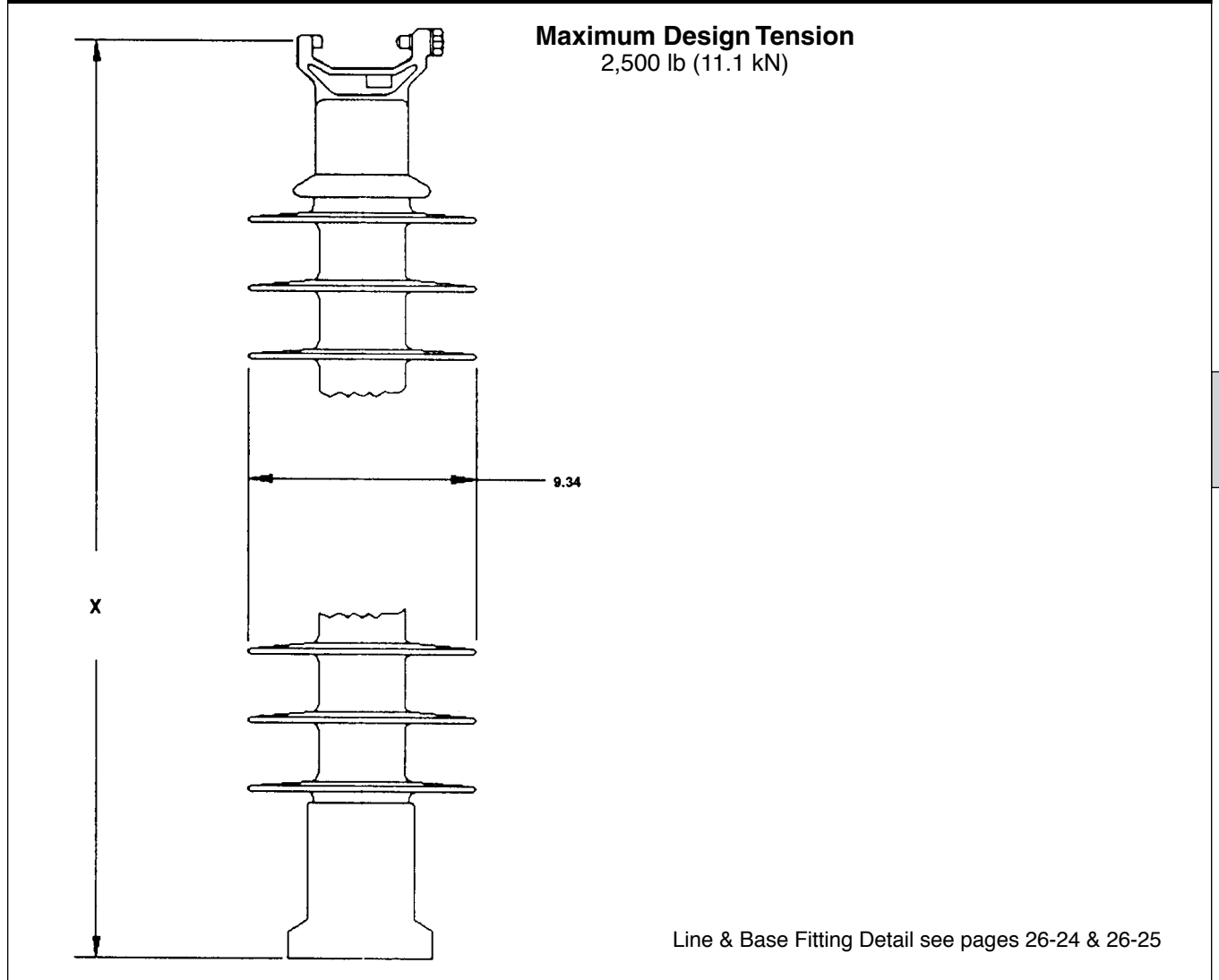
B

Selection Guide Typical Line Voltage, kV				Catalog # with 5" Bolt Circle & Vert. Clamptop	"X" Length Inches (mm)	No. of Sheds	Dry Arc Distance inches (mm)	Leakage Distance inches (mm)	<sup>(1)</sup> 60 Flashover ANSI		<sup>(1)</sup> Critical Flashover ANSI		<sup>(2)</sup> RCL pounds (kN)	Net Weight pounds (kg)
									Dry-kV	Wet-kV	Pos-kV	Neg-kV		
69	115	138	161	5230051205	38.0 (965)	10	29 (737)	77 (1956)	295	250	445	540	2500 (11.1)	54 (24.5)
				5230061205	43.2 (1097)	12	34 (864)	93 (2362)	345	295	530	620	2500 (11.1)	59 (26.8)
				5230071205	48.5 (1219)	14	39 (991)	108 (2743)	395	335	615	705	2500 (11.1)	64 (29.1)
				5230081205	53.8 (1367)	16	45 (1143)	124 (3150)	445	380	695	785	2500 (11.1)	69 (31.4)
				5230091205	59.2 (1504)	18	50 (1270)	140 (3556)	495	420	780	870	2500 (11.1)	74 (33.6)
				5230101205	64.5 (1638)	20	55 (1397)	156 (3962)	545	465	865	950	2335 (10.4)	79 (35.9)

Notes: (1) Tests in accordance with ANSI C29.1-1982.  
 (2) RCL is the maximum cantilever continuous load at which the post should be applied.

### Hi\*Lite XL 3.0" Rod Dia. Base Fittings

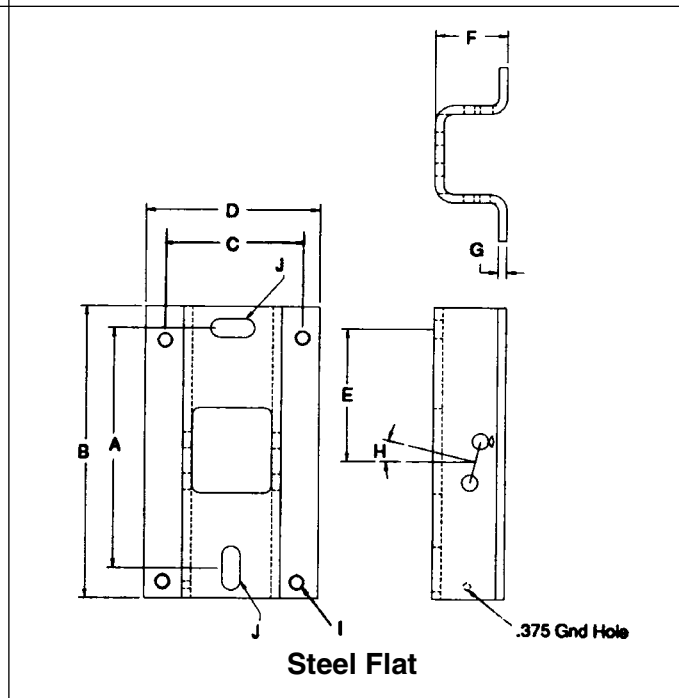
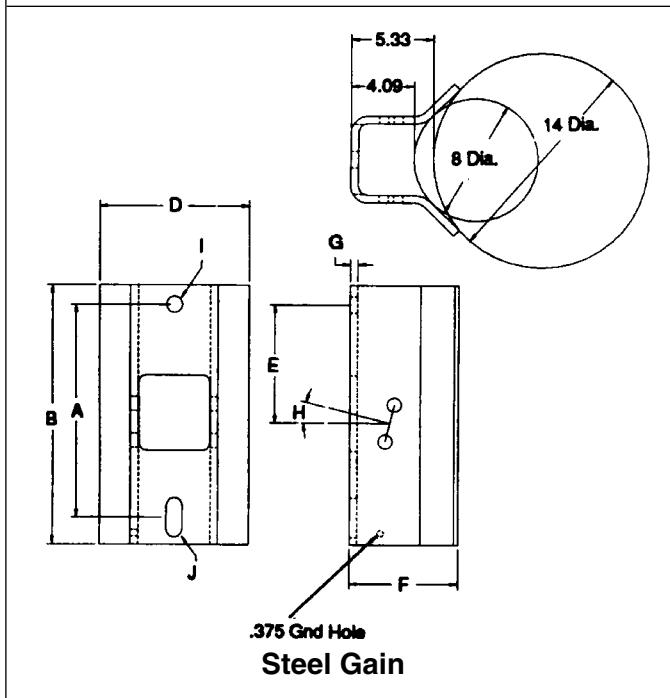
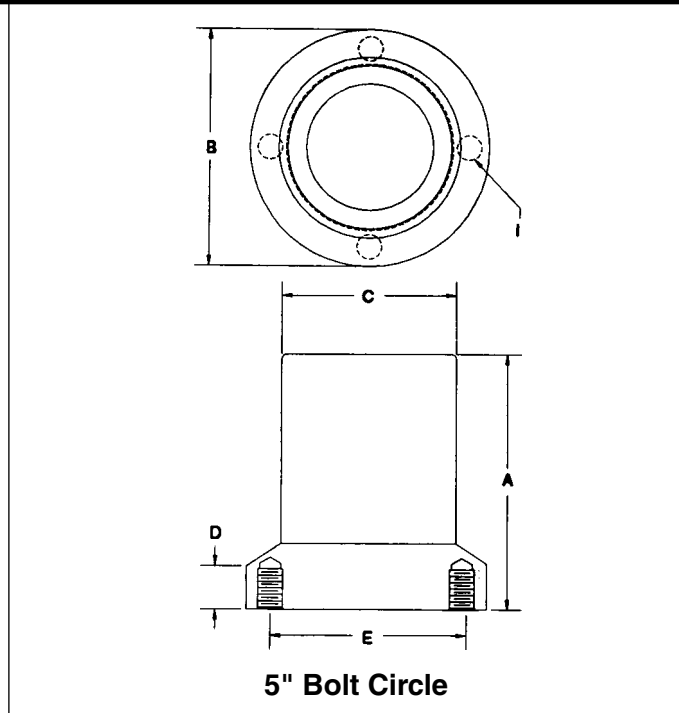
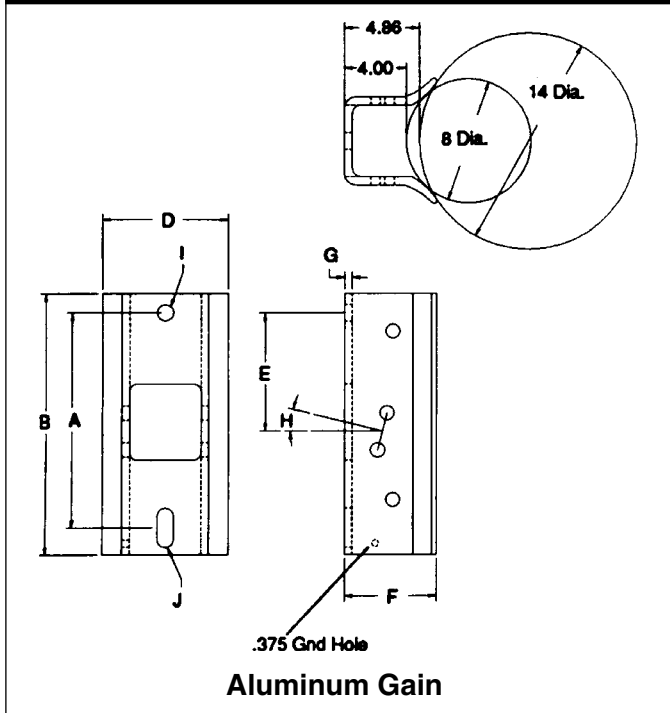

#### Horizontal & Vertical Bases Dimensions (in inches)

Type (Code)*	A	B	C	D	E	F	G	H	I	J	Material
5" B.C. (05)	6.36	5.9	4.37	1.2	5.0	-	-	-	5/8 - 11 UFS	-	60-40-18 D.I.
Al Gain (02)	14.0	17.0	-	8.079	7.75	5.949	0.53	14°	1.06	1.06 x 2.56	6063 T5 Al
Steel Gain (07)	14.0	17.0	-	9.65	7.75	7.03	0.5	14°	1.06	1.06 x 2.56	Low Carbon Steel
Steel Flat (08)	13.0	15.0	9.0	11.0	6.5	4.12	0.5	14°	0.938	-	Low Carbon Steel
Steel Flat (04)	14.0	17.0	-	10.0	7.75	4.12	0.5	14°	-	1.06 x 2.56	Low Carbon Steel

\*Code is the 2nd number in the Suffix Code of the Catalog Number.



## Hi\*Lite XL 3.0" Rod Dia. Line Fittings

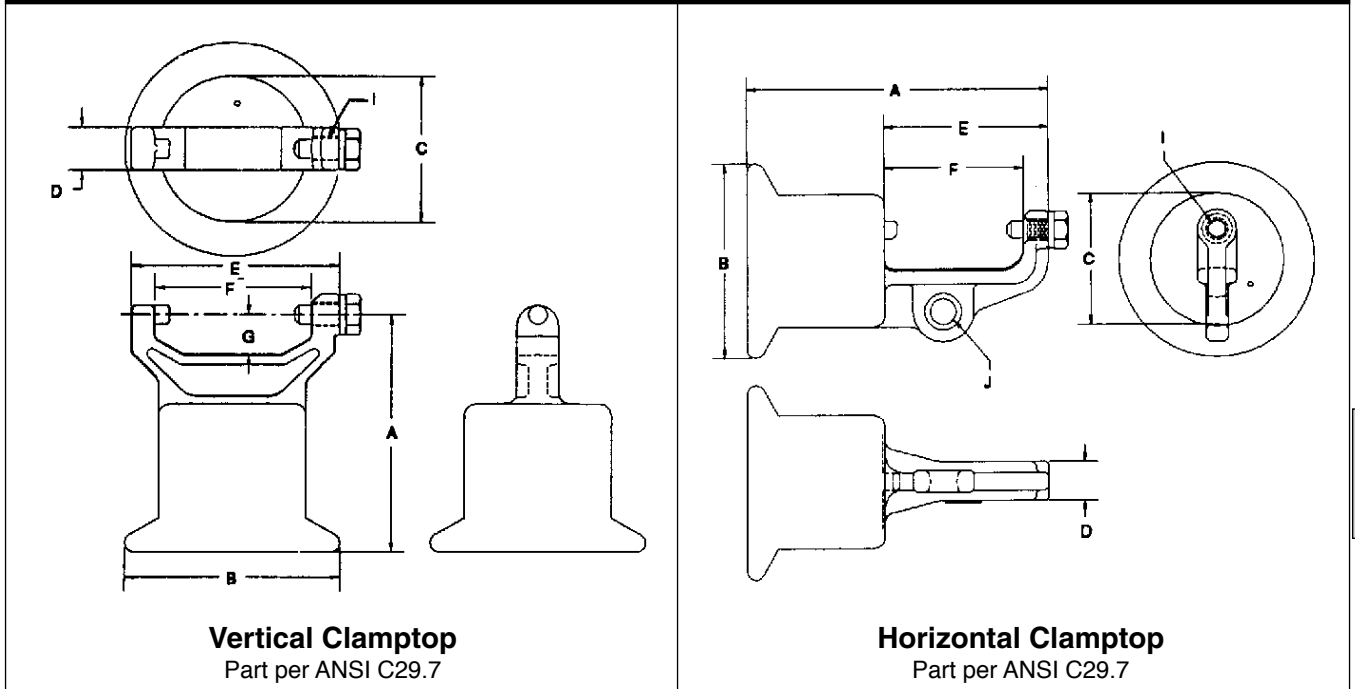

B

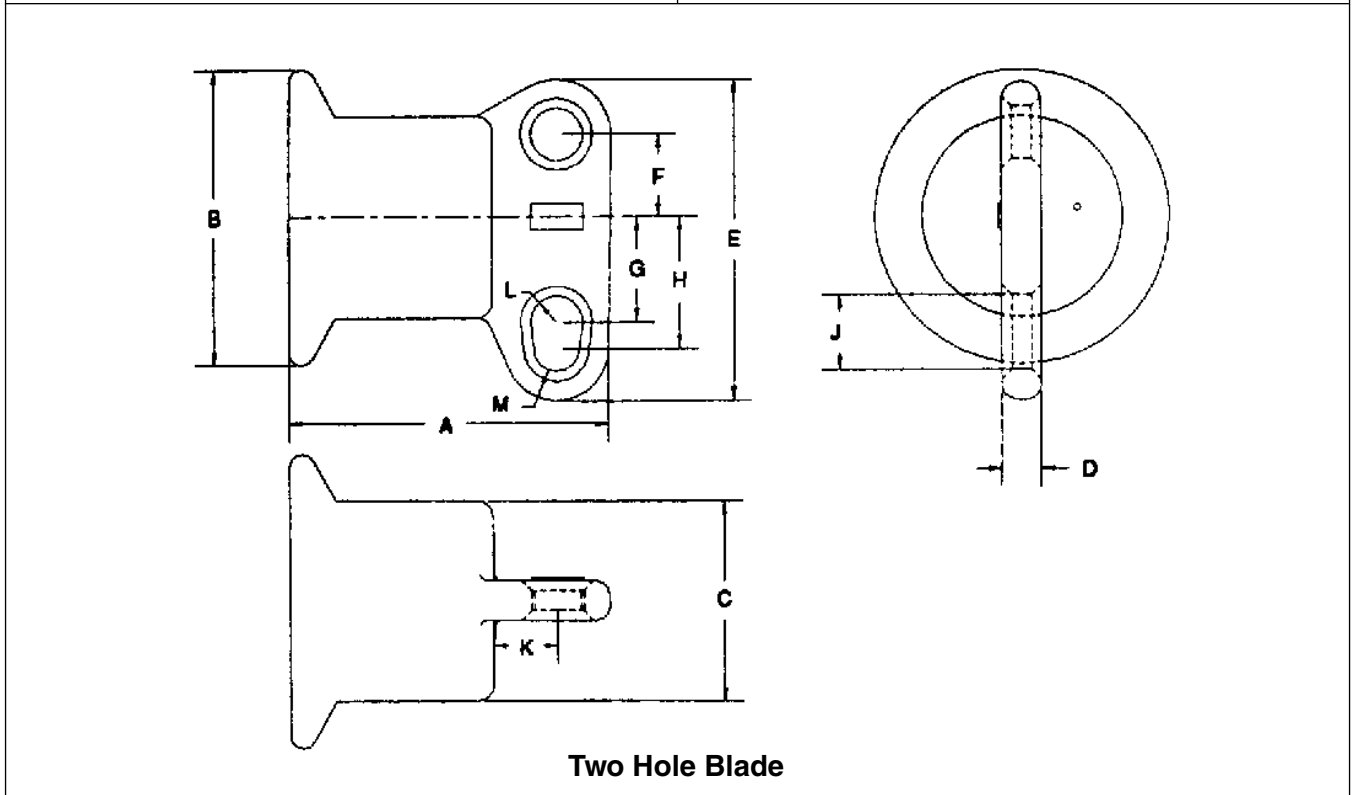

**Horizontal & Vertical End Fittings** Dimensions (in inches)

Type (Code)*	A	B	C	D	E	F	G	H	I	J	K	L	M	Material
2 Hole End (0)	6.16	5.63	3.84	0.75	6.12	1.57	2.0	2.5	-	1.44	1.24	0.5R	0.44 R	60-40-18 D.I.
H. Clamptop (1)	8.64	5.63	3.84	1.12	4.72	4.0	-	-	5/8 - 11 UFS	0.75	-	-	-	60-40-18 D.I.
V. Clamptop (2)	6.31	5.63	3.84	1.12	5.37	4.0	1.06	-	5/8 - 11 UFS	-	-	-	-	60-40-18 D.I.

\*Code is the 2nd digit in the Suffix Code of the Catalog Number.

## Clamptop Clamp

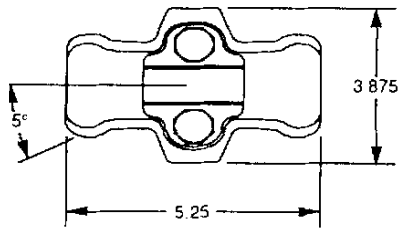

Figure 1

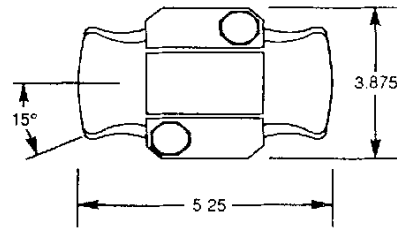
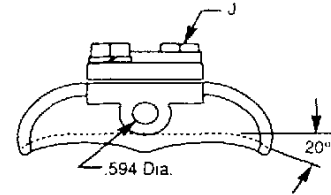
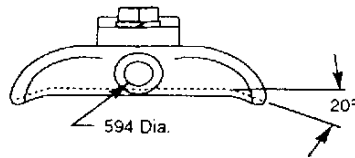

Figure 2



Clamptop clamps can be mounted directly on Hi\*Lite XL 250 posts if the posts are ordered with the horizontal or vertical clamptop option.

Catalog Number	Fig. No.	Body & Keeper Material	Clamping Range Inches (mm)	Ultimate Body Strength Lbs. (kN)
TSC57	1	356-T6 Al	0.25-057 (6.3-14.4)	2800 (1.273)
TSC106	1	356-T6 Al	0.50-1.06 (12.7-26.9)	2800 (1.273)
TSC150	1	356-T6 Al	1.00-1.50 (25.4-38.1)	2800 (1.273)
TSC200	2	356-T6 Al	1.50-2.00 (38.1-50.8)	2800 (1.273)

## Jumper Clamps and Assemblies

A practical application of Hi\*Lite line posts is for support of jumper loops on transmission lines.

Horizontal motion of the jumper is restricted, and the factor of wind sway is eliminated. Additionally the crossarm length may be reduced. The Difference in cost of insulation is not significant but, the savings in tower cost can be attractive. Regardless of cost, the use of a jumper support improves construction.

If using a single clamp, clamp position relative to the insulator may be changed by bolting the clamp through the upper hole in the insulator end fitting.

**Jumper clamps are not intended for tangent span applications.**

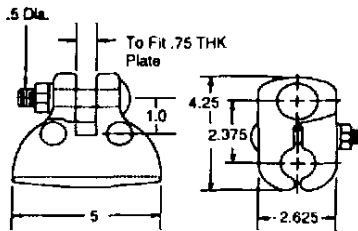

Figure 1

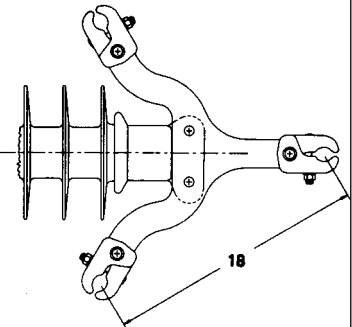

Figure 3

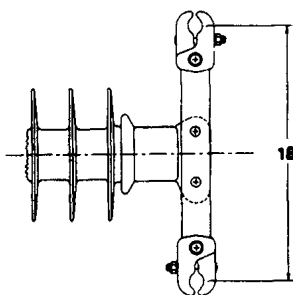

Figure 2

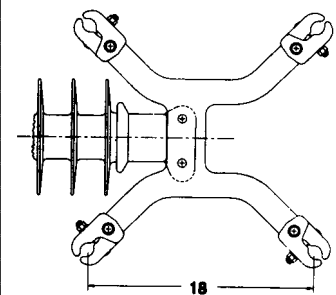
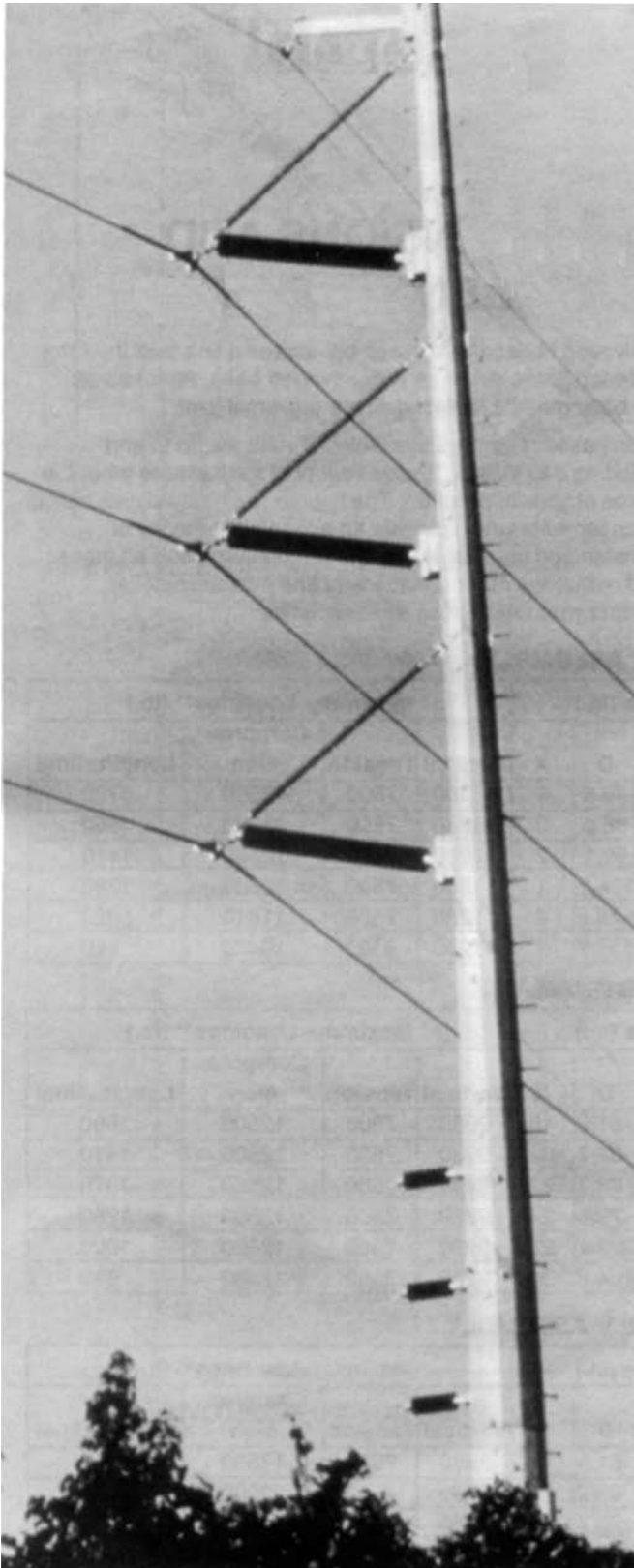

Figure 4

Figure	Catalog Number	Yoke Type	Clamping Range (Inches)	Post Type
1	976423002	None	1.00 - 1.40	Any
1	976423003	None	1.40 - 1.60	Any
1	600643001	None	1.60 - 2.00	Any
2	2717243001	Dual	1.00 - 1.40	250
2	2717253001	Dual	1.40 - 1.60	250
2	2717263001	Dual	1.60 - 2.00	250
2	2738383001	Dual	1.00 - 1.40	300
2	2738393001	Dual	1.40 - 1.60	300
2	2738403001	Dual	1.60 - 2.00	300
3	2721763001	Triple	1.00 - 1.40	250
3	2721773001	Triple	1.40 - 1.60	250
3	2721783001	Triple	1.60 - 2.00	250
3	2738413001	Triple	1.00 - 1.40	300
3	2738423001	Triple	1.40 - 1.60	300
3	2738433001	Triple	1.60 - 2.00	300
4	2721793001	Quad	1.00 - 1.40	250
4	2721803001	Quad	1.40 - 1.60	250
4	2721813001	Quad	1.60 - 2.00	250
4	2738443001	Quad	1.00 - 1.40	300
4	2738453001	Quad	1.40 - 1.60	300
4	2738463001	Quad	1.60 - 2.00	300



# Hi\*Lite® XL Braced Posts

## Table of Contents

	Page
Dimension and Strength Ratings.....	26-28
Assembly Drawings.....	26-29

C

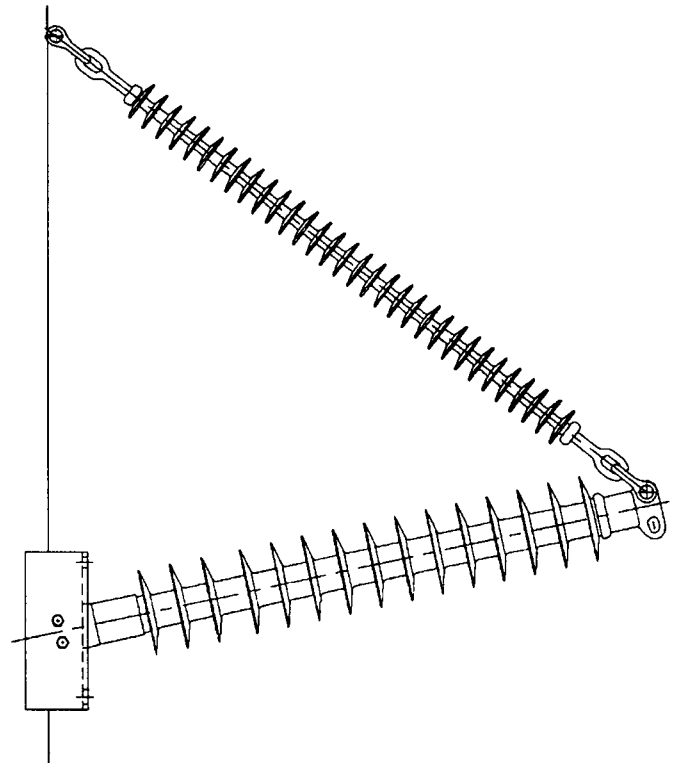

# Hi\*Lite® XL Assemblies

Catalog number covers complete assembly including insulator and hardware as illustrated.

The need to minimize the tower size and visual impact of transmission lines has prompted increased interest in braced line posts, horizontal-V, and pivoting V assemblies. These insulating structures offer vastly improved vertical load capabilities over conventional lines posts while retaining the advantages of a fixed conductor position.

A braced line post uses a conventional line post with a suspension string tied to the tower face with a link. A horizontal-V replaces the link with a fixed offset extending from the tower face adding a stabilizing force to the assembly. Both these assemblies are available with flat or gain bases.

## DIMENSIONS AND STRENGTH RATINGS

A pivoting horizontal-V assembly utilizes a line post insulator fastened to the structure with a hinged base. Alternatively, the base may be replaced with a universal joint.

These assemblies are available for voltages up to and including 345 kV with a wide variety of hardware to meet the needs of your application. The figures illustrated depict typical arrangements which provide an economical means of withstanding unusual loads. For more information on these and numerous other variations of line post assemblies, contact your Ohio Brass representative.

### BRACED LINE POST ASSEMBLY

Typical System kV	Cat # Gain Base	Cat # Flat Base	Component Insulators		Dimensions (in.)					Maximum Loadings** (lb.)			
			Post	Suspension	A	B	C	D	X	Vertical	Tension	Compression	Longitudinal
115/138	234220	234221	522008	511010	53.7	72.8	74.0	79.8	2	11280	7500	12500	1730
115/138	234222	234223	522009	511211	58.8	81.9	83.0	88.9	2	11280	7500	12500	1550
161	234224	234225	522010	511013	64.1	91.1	91.0	98.1	2	11280	7500	12500	1410
161	234226	234227	522011	511014	69.4	97.2	96.0	104.2	2	11280	7500	12500	1280
230 *	234228	234229	522014	511018	85.0	121.6	118.0	128.6	2	11280	7500	11810	1020
230 *	234230	234231	522015	511219	90.3	130.7	127.0	137.7	2	11280	7500	10470	960

### HORIZONTAL V ASSEMBLY

Typical System kV	Cat # Gain Base	Cat # Flat Base	Component Insulators		Dimensions (in.)					Maximum Loadings** (lb.)			
			Post	Suspension	A	B	C	D	X	Vertical	Tension	Compression	Longitudinal
115/138	234232	234233	522008	511007	54.9	54.6	51.0	61.6	18	9980	7500	12500	1680
115/138	234234	234235	522009	511008	60.1	60.7	56.0	67.7	20	9980	7500	12500	1510
161	234236	234237	522010	511009	65.5	66.7	61.0	73.7	22	9980	7500	12500	1370
161	234238	234239	522011	511010	70.9	72.8	66.0	79.8	24	9980	7500	12500	1250
230 *	234240	234241	522014	511013	86.9	91.1	80.0	98.1	28	9980	7500	12500	1000
230 *	234242	234243	522015	511014	92.3	97.2	85.0	104.2	30	9980	7500	12500	930

### PIVOTING HORIZONTAL V ASSEMBLY

Typical System kV	Cat # Gain Base	Cat # Flat Base	Component Insulators		Dimensions (in.)					Maximum Loadings** (lb.)			
			Post	Suspension	A	B	C	D	X	Vertical	Tension	Compression	Longitudinal
115/138	—	234244	522008	511007	55.2	54.6	51.0	61.6	18	9980	7500	12500	—
115/138	—	234245	522009	511008	60.4	60.7	56.0	67.7	20	9980	7500	12500	—
161	—	234246	522010	511009	65.8	66.7	61.0	73.7	22	9980	7500	12500	—
161	—	234247	522011	511010	71.2	72.8	66.0	79.8	24	9980	7500	12500	—
230 *	—	234248	522014	511013	87.2	91.1	80.0	98.1	28	9980	7500	12500	—
230 *	—	234249	522015	511014	92.6	97.2	85.0	104.2	30	9980	7500	12500	—

Contact your Ohio Brass representative for designs utilizing the optional pivoting strut member.

\* Corona rings are required for 230 kV and above.

\*\* Maximum loads are for single loads in the specified direction.

# Assembly Drawings

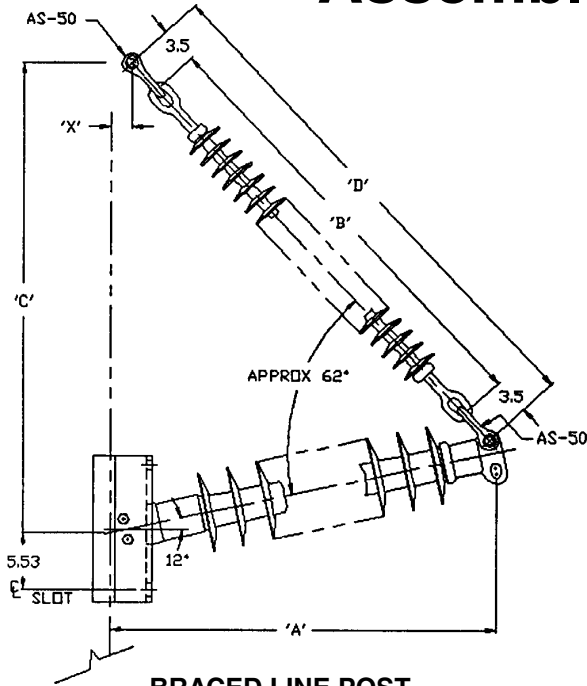

**BRACED LINE POST**

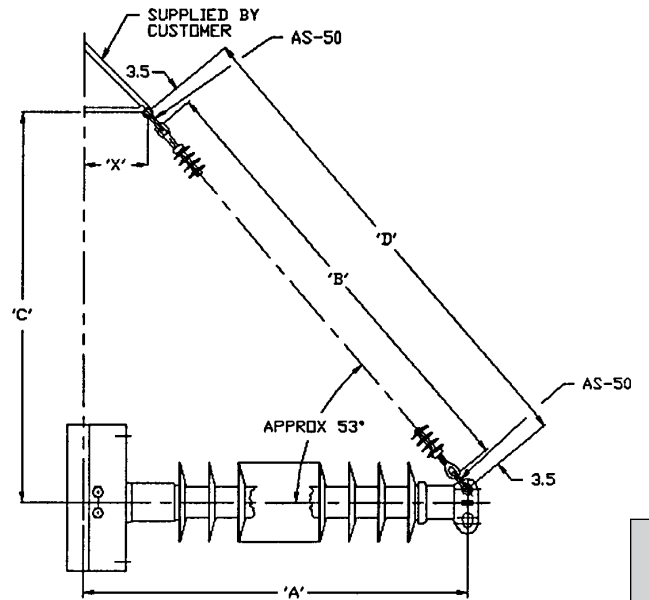

**HORIZONTAL-V**

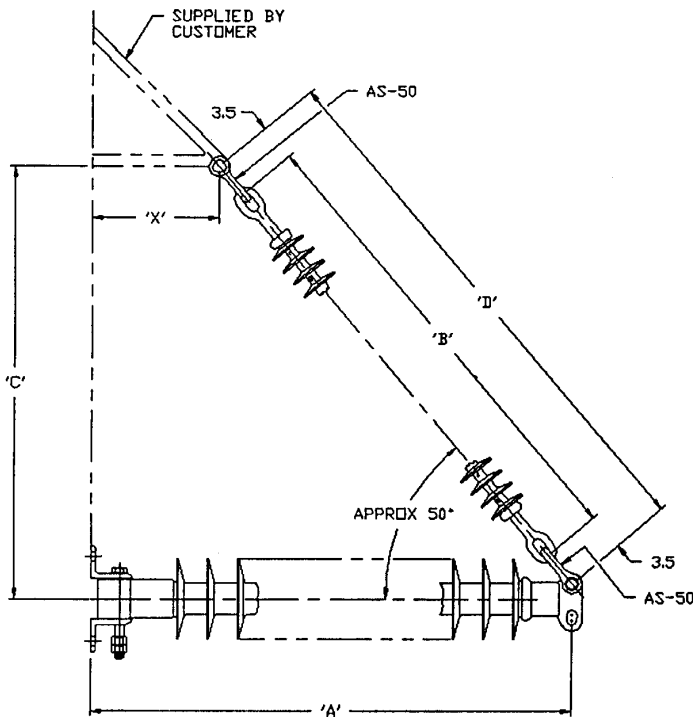

**PIVOTING HORIZONTAL-V**

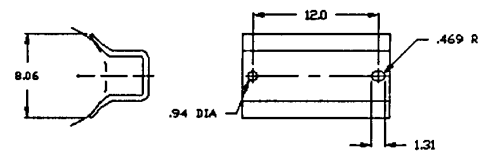

**GAIN BASE MOUNTING**

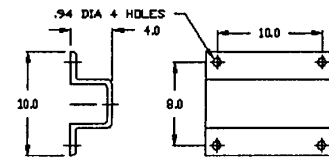

**FLAT BASE MOUNTING**

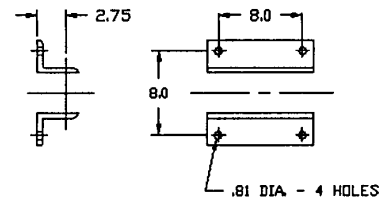

**PIVOTING BASE MOUNTING**

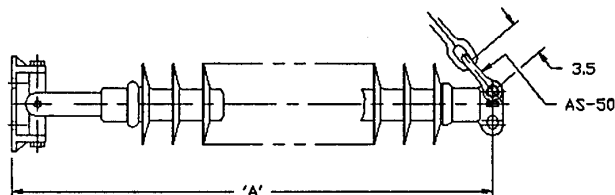

**OPTIONAL PIVOTING STRUT MEMBER**

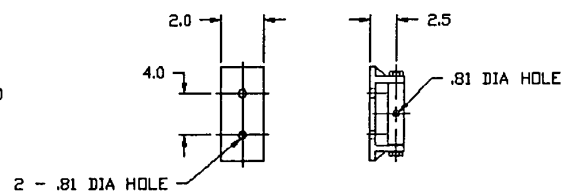



# HI\*LITE II STATION POST INSULATORS

## Table of Contents

	Page
Station Post Insulator Ratings .....	26-31
Series 175: 3" Bolt Circles .....	26-32
Series 250: 3" and 5" Bolt Circles.....	26-33

**NOTE:** Insulators listed here are Hi-Lite II design having individual weathersheds assembled to the core rod and sealed via axial compression in the polymer rubber material.

**D**

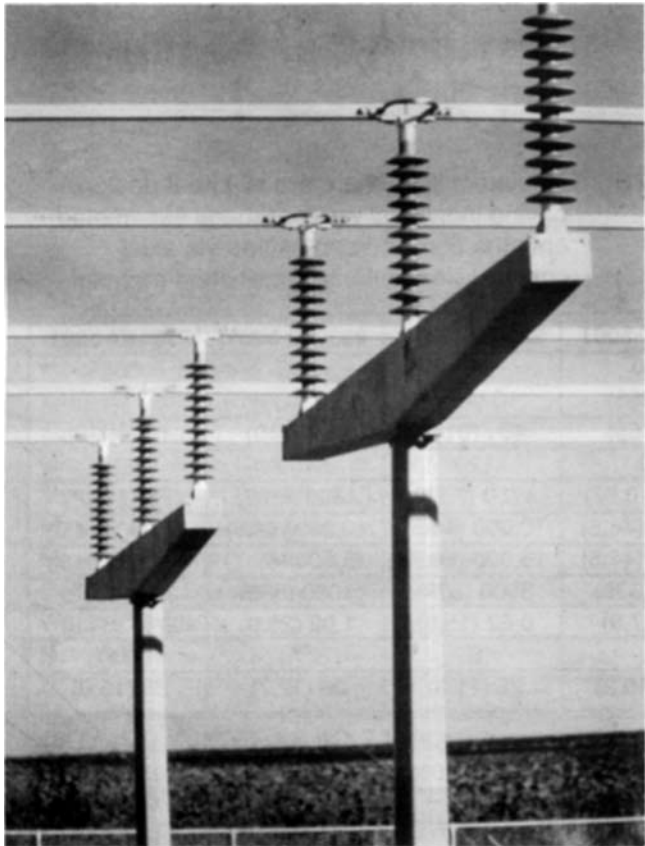

## HI-LITE II POST INSULATORS

### Maximum Design Cantilever Rating (MDC)

MDC is the maximum recommended load in cantilever that a Hi\*Lite post insulator is designed to withstand during its service life.

### Average Failing Load (AFL)

AFL is the average failing load of a Hi\*Lite line or station post insulator. This value can be determined by multiplying the MDC by a factor of 2.5.

### Selection

If you need a Hi\*Lite post that is different from those shown in this catalog, please contact your OB representative. Hi\*Lite station posts meet electrical and dimensional specifications of their porcelain equivalents. Mechanically, the Hi\*Lite are less rigid with more deflection under both cantilever and torsional loading.

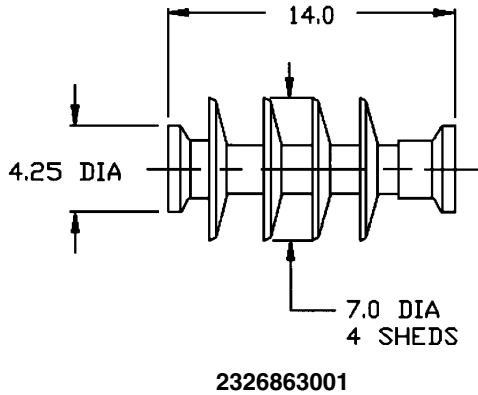

# HI\*LITE II STATION POST INSULATORS

## Series 175

3" (76mm) Bolt Circles

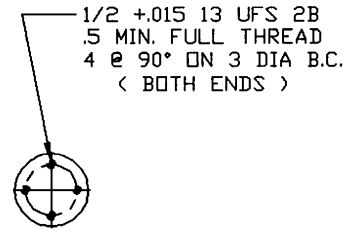

**NOTE:** Insulators listed here are Hi-Lite II design having individual weathersheds assembled onto the core rod and sealed via axial compression in the polymer shed material.

CATALOG NUMBER (3" BOLT CIRCLES)	2326863001	2326853001	2331923001	2331873001
BIL (kV)	150	200	250	350
Height — X in. (mm)	14 (356)	18 (457)	22 (559)	30 (762)
Leakage Distance in. (mm)	27 (685)	40 (1015)	49 (1240)	76 (1930)
60-Hz Withstand — 10 sec/wet (kV)	80	120	150	230
Maximum Design Cantilever lb. (kN)	2390 (10.67)	1750 (7.78)	1390 (6.23)	980 (4.39)
Maximum Design Tension lb. (kN)	10,000 (44.5)	10,000 (44.5)	10,000 (44.5)	10,000 (44.5)
Maximum Design Compression lb. (kN)	10,000 (44.5)	15,000 (66.7)	15,000 (66.7)	15,000 (66.7)
Maximum Design Torsion in.-lb. (N-meter)	3000 (339)	3000 (339)	3000 (339)	3000 (339)
Deflection at Stated Cantilever in. (mm)	0.31 (7.9)	0.62 (15.9)	1.02 (25.9)	2.16 (54.9)
Weathersheds	4	6	7	11
Net Weights lb. (kg.)	22.5 (10.2)	25 (11.3)	28 (12.7)	33 (15.0)

Note: Station Posts are also available in non-standard section lengths.  
Contact your Ohio Brass representative.



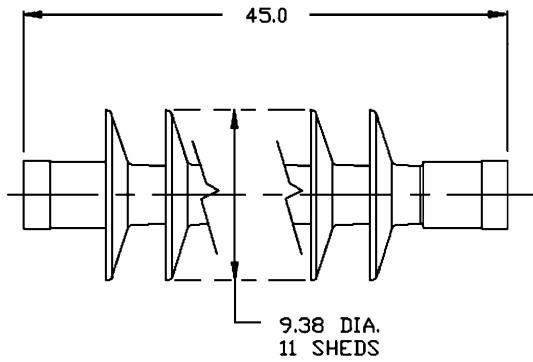
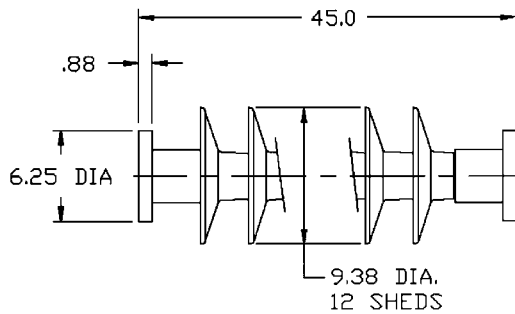

**2321993001**

**2323373001**

# HI\*LITE II STATION POST INSULATORS

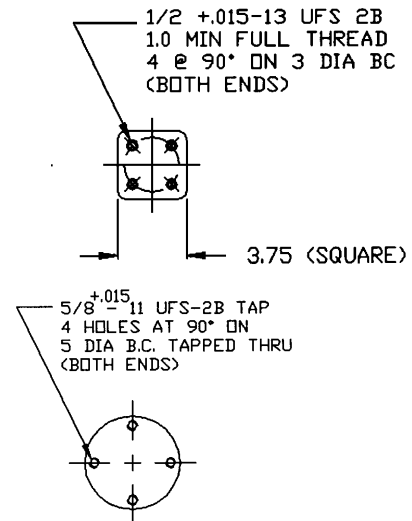
## Series 250

5" (127mm) Bolt Circles

**D**

CATALOG NUMBER (3" BOLT CIRCLES)	2323013001	2321993001	2323003001	2323093001
BIL (kV)	350	550	650	750
Height — X in. (mm)	30 (762)	45 (1143)	54 (1372)	62 (1575)
Leakage Distance in. (mm)	63 (1570)	102 (2590)	128 (3250)	148 (3760)
60-Hz Withstand — 10 sec/wet (kV)	190	300	380	430
Maximum Design Cantilever lb. (kN)	1400 (6.23)	930 (4.14)	770 (3.42)	670 (2.98)
Maximum Design Tension lb. (kN)	30,000 (133)	30,000 (133)	30,000 (133)	30,000 (133)
Maximum Design Compression lb. (kN)	50,000 (222)	50,000 (222)	50,000 (222)	50,000 (222)
Maximum Design Torsion in.-lb. (N-meter)	9,000 (1000)	9,000 (1000)	9,000 (1000)	9,000 (1000)
Deflection at Stated Cantilever in. (mm)	1.0 (25)	2.3 (58)	3.4 (86)	4.5 (114)
Weathersheds	7	11	14	16
Net Weights lb. (kg.)	30 (13.6)	42 (19)	51 (23)	54 (24.5)

CATALOG NUMBER (5" BOLT CIRCLES)	2323363001	2323373001	2323383001	2323393001	2323753001
BIL (kV)	350	550	650	750	900
Height — X in. (mm)	30 (762)	45 (1143)	54 (1372)	62 (1575)	80 (2032)
Leakage Distance in. (mm)	64 (1626)	109 (2770)	130 (3300)	156 (3960)	204 (5180)
60-Hz Withstand — 10 sec/wet (kV)	190	320	380	450	560
Maximum Design Cantilever lb. (kN)	2900 (12.90)	1850 (8.23)	1520 (6.76)	1310 (5.83)	990 (4.45)
Maximum Design Tension lb. (kN)	30,000 (133)	30,000 (133)	30,000 (133)	30,000 (133)	30,000 (133)
Maximum Design Compression lb. (kN)	50,000 (222)	50,000 (222)	50,000 (222)	50,000 (222)	35,000 (156)
Maximum Design Torsion in.-lb. (N-meter)	9000 (1000)	9000 (1000)	9000 (1000)	9000 (1000)	9,000 (66.7)
Deflection at Stated Cantilever in. (mm)	1.77 (45)	4.13 (105)	6.00 (152)	8.00 (203)	13.50 (343)
Weathersheds	8	12	14	17	22
Net Weights lb. (kg.)	30 (13.6)	42 (19)	51 (23)	54 (24.5)	72 (32.7)

- Notes: 1. Station Posts are also available in non-standard section lengths. Contact Ohio Brass.  
 2. At 230 kV, corona ring 2721273001 may be required.  
 3. For through holes, specify code 3002.



## Sample Polymer Specification

Purpose: To ensure a suitable service life of polymer insulating materials.

### I. Material Design Tests

- The following must be performed to certify a material for use in production.

**1. Tracking test:** Performed on a sample of material inclined at 30° and electrodes positioned 35mm apart. Samples are sprayed with a conductive solution (400Ωcm) and energized at 10kV. The cycle is repeated every 90 seconds. The sample passes if there is:

1. No carbonization or tracking.
2. No erosion through sample.
3. No leakage current flow at the end of 90 seconds.

The sample must withstand 15,000 test cycles.

**2. Ultraviolet Test:** Samples of the rubber must be tested in a QUV tester or equivalent cyclic weatherometer. The samples are exposed to high ultraviolet radiation and high humidity without cracking, checking or becoming hydrophilic.

The sample is judged to have passed this test if it exceeds 8,000 hours of exposure without damage.

**3. Corona Cutting:** Samples 5 cm by 7 cm are subjected to mechanical stress of 300,000  $\mu$ strain by bending samples around a grounded electrode. A needle-like electrode is placed 1 mm from the surface of the sample and energized at 12 kV in a controlled humidity chamber.

The sample is judged to have passed this test if there is no splitting or cutting. Samples must pass 1,000 hours of exposure to this test.

**4. Oxidative Stability:** Samples of the polymer compound are tested using differential scanning calorimetry. Samples are heated rapidly in a nitrogen atmosphere to the test temperature of 200°C. The atmosphere is then changed to air and the temperature is maintained until the antioxidant is consumed, as measured by an exothermic chemical reaction. The time to this reaction must exceed 300 minutes.

**5. Tear Strength:** Rubber test slabs are prepared in accordance with ASTM Standards and are tested to determine tear strength of the material. The minimum acceptable tear strength is 150 lb./in.

### II. Other Requirements

- The manufacturer must supply upon request a listing of routine tests performed to ensure production compliance with design tests.

**E**

**POWER SYSTEMS, INC.**

**WORLDWIDE LOCATIONS**

**Web: <http://www.hubbellpowersystems.com>**  
**E-mail: [hpsliterature@hps.hubbell.com](mailto:hpsliterature@hps.hubbell.com)**

**UNITED STATES**

HUBBELL POWER SYSTEMS, INC.  
 210 N. Allen  
 Centralia, Mo 65240-1395  
 Phone: 573-682-5521  
 Fax: 573-682-8714  
 e-mail: [hpsliterature@hps.hubbell.com](mailto:hpsliterature@hps.hubbell.com)

**CANADA**

HUBBELL CANADA LP  
 870 Brock Road South  
 Pickering, Ontario L1W 1Z8  
 Phone: 905-839-1138  
 Fax: 905-831-6353  
 e-mail: [infohps@hubbellonline.com](mailto:infohps@hubbellonline.com)

**MEXICO**

HUBBELL DE MEXICO, S.A. DE. CV  
 Av. Coyoacan No. 1051  
 Col. Del Valle  
 03100 Mexico, D.F.  
 Phone: 52-55-9151-9999  
 Fax: 52-55-9151-9988  
 e-mail: [vtasdf@hubbell.com.mx](mailto:vtasdf@hubbell.com.mx)

**ANDERSON™ CHANCE® FARGO® OHIO/BRASS® QUAZITE®**